

Die Components OMCR  
OMCR Normalien  
Componenti OMCR

**OMCR**<sup>®</sup>  
STANDARD DIE COMPONENTS

# Die Components Werkzeugkomponenten Componenti per Stampi

Ⓜ **OMCR**'s line of die components offers an extraordinary variety of items meeting the standards of the leading automotive manufacturers. Thanks to the widespread use of computerised management systems, flexible production systems and wide availability of items in stock, this range of products meets the majority of customers needs and ensures quality, reliability and quick delivery. In this **Die Components** range we offer the **OMCR Standard** series, results of a selection which has allowed us to identify the ideal standard items for an efficient design and manufacture of dies for working sheet metal.

Ⓜ Die Linie der **Werkzeugkomponenten** bietet eine außergewöhnliche Vielfalt an Artikeln, die den Normen der europäischen Automobilhersteller entsprechen. Dank der EDV-gestützten Steuerung des Unternehmens, flexibler Produktionssysteme und durch einen großen Bestand an fertigen Produkten im Lager deckt diese Produktreihe den Bedarf der Kunden in vollem Umfang ab und gewährleistet Qualität, Zuverlässigkeit und schnelle Lieferung.

Unsere **Werkzeugkomponenten** beinhalten auch die Serie **Standard OMCR**, eine Auswahl an Normalien zur effizienten Konstruktion von Stanzwerkzeugen.

Ⓜ La linea **Componenti per Stampi** offre una straordinaria varietà di articoli, conformi alle normative delle principali case automobilistiche. Grazie al diffuso utilizzo di sistemi informatici di gestione, di sistemi di produzione flessibili e all'ampia disponibilità di prodotti pronti a magazzino, questa gamma di prodotti risponde in modo esauriente alle necessità dei clienti e garantisce qualità, affidabilità e rapidità nelle consegne.

All'interno della linea **Componenti per Stampi**, proponiamo la serie **Standard OMCR**, frutto di una selezione che ha permesso di individuare i normalizzati ideali per un'efficiente progettazione di stampi lavorazione lamiera.



# OMCR<sup>®</sup>

STANDARD DIE COMPONENTS



<p><b>C10.09</b></p> 	<p><b>C10.10</b></p> 	<p><b>C10.11</b></p> 	<p><b>C10.12</b></p> 	<p><b>C10.13</b></p> 
<p>BMW-MERCEDES-BENZ- FCA-FORD-OPEL-VW/AUDI</p>	<p>BMW-MERCEDES-BENZ- FCA-FORD-OPEL-VW/AUDI</p>			<p>MERCEDES-BENZ</p>
<p>Gage hardened Einweiser gehärtet Riferimento indurito</p>	<p>Gage Einweiser Riferimento</p>	<p>Gage for sensor Einweiser für Teillagekontrolle Riferimento per sensore</p>	<p>Gage Einweiser Riferimento</p>	<p>Gage hardened Einweiser gehärtet Riferimento indurito</p>
<p>20</p>	<p>21</p>	<p>22</p>	<p>23</p>	<p>24</p>
<p><b>C10.14</b></p> 	<p><b>C10.15</b></p> 	<p><b>C10.16</b></p> 	<p><b>C10.18</b></p> 	<p><b>C10.20</b></p> 
<p>MERCEDES-BENZ</p>	<p>BMW - FCA</p>	<p>VW/AUDI</p>	<p>BMW - MERCEDES-BENZ</p>	<p>FCA - OPEL</p>
<p>Gage Einweiser Riferimento</p>	<p>Gage for sensor Einweiser für Teillagekontrolle Riferimento per sensore</p>	<p>Gage Feineinweiser Riferimento di precisione</p>	<p>Gage Einweiser Riferimento</p>	<p>Front gage Einlaufanschlag Portasensore</p>
<p>24</p>	<p>25</p>	<p>26</p>	<p>27</p>	<p>28</p>
<p><b>C10.25</b></p> 	<p><b>C10.30</b></p> 	<p><b>C10.90</b></p> 	<p><b>C10.91</b></p> 	<p><b>C10.92</b></p> 
<p>VW/AUDI</p>				
<p>Support for sensor Lagekontrolle für Platinen Supporto sensore</p>	<p>Gage Einweiser Riferimento</p>	<p>Sensor Induktive sensor Sensore</p>	<p>Connector Steckverbinder Connettore</p>	<p>Sensor Inductive sensor Sensore</p>
<p>29</p>	<p>31</p>	<p>32</p>	<p>33</p>	<p>34</p>
<p><b>C10.95</b></p>  <p>RANGE EXTENSION</p>	<p><b>C11.08</b></p> 	<p><b>C11.09</b></p> 	<p><b>C11.11</b></p> 	<p><b>C11.12</b></p> 
<p>VW/AUDI</p>		<p>FCA - VW/AUDI</p>	<p>FCA - VW/AUDI</p>	<p>FCA</p>
<p>Plate for sensor Halterung Piastrina portasensore</p>	<p>Locating cone Kegeldistanz Cono di centraggio</p>	<p>Locating cone Kegeldistanz Cono di centraggio</p>	<p>Locating cone Kegeldistanz Cono di centraggio</p>	<p>Locating pin Zentrierbolzen Perno di centraggio</p>
<p>35</p>	<p>36</p>	<p>38</p>	<p>40</p>	<p>42</p>



<b>C11.15</b>  BMW	<b>C11.20</b>  BMW - VW/AUDI	<b>C11.30</b>  VW/AUDI	<b>C11.31</b>  FCA	<b>C11.32</b>  FCA
Locating pin Zentrierbolzen Perno di centraggio 42	Locating pin Zentrierbolzen Perno di centraggio 43	Visual locator setting punch Endkontrollstempel Punzone di visualizzazione 44	Visual locator punch Endkontrollstempel Punzone di visualizzazione 45	Adjustment plate Scheibe Rondella di registro 46
<b>C11.33</b>  FORD	<b>C11.40</b>  FCA-PSA-RENAULT	<b>C11.45</b>  FCA-PSA-RENAULT	<b>C11.50</b>  FCA-PSA-RENAULT	<b>C11.51</b>  FCA - PSA - RENAULT
Visual locator punch Endkontrollstempel Punzone di visualizzazione 46	Stamp retainer Halteplatte Portatimbrì 47	Backing plate Druckplatte Reazione 48	Stamp Buchstabenstempel Punzone marchio 49	Stamp Buchstabenstempel Punzone marchio 50
<b>C12.10.?</b>  BMW - FORD - OPEL	<b>C12.11.?</b>  VW/AUDI	<b>C12.11.?</b>  VW/AUDI	<b>C12.12</b>  BMW - MERCEDES BENZ	<b>C12.12</b>  BMW - MERCEDES BENZ
Air pin Druckbolzen Candela 51	Air pin Unterluftbolzen Candela 52	Air pin Unterluftbolzen Candela 53	Air pin Unterluftbolzen Candela 54	Air pin Unterluftbolzen Candela 55
<b>C12.12</b>  BMW - MERCEDES BENZ	<b>C12.12.?</b>  BMW - MERCEDES BENZ	<b>C12.16</b>  BMW VW/AUDI	<b>C12.20</b>  FCA	<b>C12.21</b>  FCA
Air pin Unterluftbolzen Candela 56	Air pin Unterluftbolzen Candela 57	Spacer plate toothed Distanzplatte gezahnt Tassello di compensazione 58	Compensation block Abstandsblock Tassello di compensazione 59	Shim Ausgleichscheib Spessore 59

<b>C12.22</b>	<b>C12.23</b>	<b>C12.24</b>	<b>C12.25</b>	<b>C12.26</b>
				
<p>OPEL</p>		<p>BMW</p>	<p>FORD</p>	<p>VW/AUDI</p>
<p>Pressure plate Druckplatte Piastra di reazione</p>	<p>Pressure plate Druckplatte Piastra di reazione</p>	<p>Pressure plate Druckplatte Piastra di reazione</p>	<p>Balance block Distanzstück Distanziale</p>	<p>Balance block Distanzstück Distanziale</p>
<p>60</p>	<p>61</p>	<p>62</p>	<p>63</p>	<p>64</p>
<b>C12.26.?</b>	<b>C12.27</b>	<b>C12.27.?</b>	<b>C12.28</b>	<b>C12.30</b>
				
<p>VW/AUDI</p>	<p>VW/AUDI</p>	<p>VW/AUDI</p>	<p>PSA</p>	<p>VW/AUDI</p>
<p>Balance block Distanzstück Distanziale</p>	<p>Balance block Distanzstück Distanziale</p>	<p>Balance block Distanzstück Distanziale</p>	<p>Balance block Distanzstück Distanziale</p>	<p>Spacing bar Abstellbolzen Distanziale</p>
<p>66</p>	<p>68</p>	<p>70</p>	<p>72</p>	<p>74</p>
<b>C12.30.?</b>	<b>C13.10</b>	<b>C13.11</b>	<b>C13.20.?</b>	<b>C13.24</b>
				
<p>VW/AUDI</p>	<p>VW/AUDI</p>	<p>VW/AUDI</p>	<p>FCA - FORD</p>	<p>VW/AUDI</p>
<p>Spacing bar Abstellbolzen Distanziale</p>	<p>Pad retainer pin VDI 3365 Steckbolzen VDI 3365 Perno di arresto VDI 3365</p>	<p>Pad retainer pin VDI 3365 Steckbolzen VDI 3365 Perno di arresto VDI 3365</p>	<p>Retainer bolt Zugbolzensatz Gruppo tirante</p>	<p>Ground collar screw Schraube mit distanzrohr Vite con colletto</p>
<p>76</p>	<p>78</p>	<p>79</p>	<p>80</p>	<p>82</p>
<b>C13.25.?</b>	<b>C13.26.?</b>	<b>C13.27</b>	<b>C13.30</b>	<b>C14.09</b>
				
<p>VW/AUDI</p>	<p>FORD</p>	<p>BMW - VW/AUDI</p>	<p>VW/AUDI</p>	<p>VW/AUDI</p>
<p>Pad retainer Halteelement Gruppo tirante</p>	<p>Pad retainer Halteelement Gruppo tirante</p>	<p>Anti-rebound pad retainer Halteelement mit Dämpfung Gruppo tirante antirimbalzo</p>	<p>Collar screw Schulter-passschraube Vite con colletto</p>	<p>Key Passfeder Chiavetta di reazione</p>
<p>84</p>	<p>84</p>	<p>85</p>	<p>88</p>	<p>89</p>

<b>C14.10</b>  FCA Key Passfeder Chiavetta di reazione 90	<b>C14.11</b>  FORD Retainer Haltestück Ritegno per matrice 90	<b>C14.20</b>  Key Passfeder Chiavetta di reazione 91	<b>C14.25</b>  Key Passfeder Chiavetta di reazione 92	<b>C14.28</b>  VW/AUDI Key Passfeder Chiavetta 93
<b>C14.30</b>  VW/AUDI Locating block Fangbacke Tassello di centraggio 94	<b>C15.10</b>  FCA Clamp Befestigungselement Morsetto 95	<b>C15.11</b>  FCA Sleeve Führungseinheit Canotto guida 95	<b>C15.12</b>  FCA Guide post Führungssaule Colonna 96	<b>C15.13</b>  FCA Union nut Befestigungselement Dado di unione 97
<b>C15.14</b>  Air coupling bracket Luftanschlussblock Supporto innesti rapidi 98	<b>C15.15</b>  Flux control Verteilerblock Regolatore di flusso 99	<b>C16.18</b>  VW/AUDI Roller Rolle Rotella 100	<b>C16.19</b>  VW/AUDI Roller Rolle Rotella 100	<b>C16.20</b>  VW/AUDI Roller stock lifter Federnde laufrolle Rollino sollevamento nastro 101
<b>C16.20</b>  VW/AUDI Roller stock lifter Federnde laufrolle Rollino sollevamento nastro 102	<b>C16.21</b>  FCA Roller group Förderrolle Gruppo rullini 103	<b>C16.25</b>  Coil support Abstreifer Sollevatore nastro 104	<b>C16.26</b>  FCA Ball caster Kugelrollensystem Sfera portante 105	<b>C16.27</b>  BMW - MERCEDES-BENZ Coil guide roller Führungsrolle Guida nastro 106

<p><b>C16.30</b></p> 	<p><b>C16.31</b></p> 	<p><b>C16.40</b></p> 	<p><b>C16.45</b></p> 	<p><b>C16.50</b></p> 
		FCA		VW/AUDI
Flange lifter Abstreifer Sflangiatore	Flange lifter Abstreifer Sflangiatore	Spring plunger Federne druckstücke Espulsore a molla	Spring plunger Federne druckstücke Espulsore a molla	Spring rams Federbolzen Sollevatore
107	108	109	110	111
<p><b>C17.10</b></p> 	<p><b>C17.11</b></p> 	<p><b>C17.15</b></p> 	<p><b>C17.16</b></p> 	<p><b>C17.17</b></p> 
FCA - PSA				
Elastomer spring Elastomerfeder Molla in elastomero	Elastomer spring Elastomerfeder Molla in elastomero	Elastomer stripper Abstreifer Estrattore per punzoni	Washer Scheibe Rondella	Elastomer spring Elastomerfeder Molla in elastomero
112	115	118	118	119
<p><b>C17.18</b></p> 	<p><b>C17.19</b></p> 	<p><b>C17.20</b></p> 	<p><b>C17.21</b></p> 	<p><b>C17.27</b></p> 
		FCA - PSA	OPEL	BMW - VW/AUDI
Stripping unit - Pressure plate Abstreifer - Druckplatte Piastra premende dell'estrattore	Stripping unit - Mounting plate Abstreifer - Halteplatte Piastra di fissaggio dell'estrattore	Elastomer cap Elastomerdruckstück Puntalino in elastomero	Shock absorber Halteelement Ammortizzatore	Anti-rebound elastomer Dämpfungselement Ammortizzatore antirimbalzo
120	120	121	121	122
<p><b>C17.30</b></p> 	<p><b>C17.31</b></p> 	<p><b>C17.32</b></p> 	<p><b>C17.40</b></p> 	<p><b>C17.51</b></p> 
		FCA - VW/AUDI		
Elastomer spring pin Aufnahmebolzen Perno per molle in elastomero	Washer for elastomer spring Federscheibe Rondella per molle in elastomero	Column DIN 9835 Führungsbolzen DIN 9835 Colonna di guida DIN 9835	Stripper for blanking dies Abstreifer für Platinenschnitte Estrattore per stampi	Anti-rebound elastomer Dämpfungselement Ammortizzatore antirimbalzo
123	124	125	126	127

<p><b>C17.52</b></p> 	<p><b>C18.05</b></p> 	<p><b>C18.06</b></p> 	<p><b>C18.07</b></p> 	<p><b>C18.10</b></p> 
<p>BMW</p>	<p>VW/AUDI - BMW</p>	<p>VW/AUDI</p>	<p>BMW</p>	<p>FCA</p>
<p>Anti-rebound elastomer Dämpfungselement Ammortizzatore antirimbalzo</p>	<p>Anti-rebound slide stop Arretierung gegen Rückfederung Arresto anti rimbalzo</p>	<p>Slide stop block Schieberanschlag Arresto slitta</p>	<p>Anti-rebound slide stop Arretierung gegen Rückfederung Arresto anti rimbalzo</p>	<p>Slide stop block Schieberanschlag Arresto slitta</p>
<p>128</p>	<p>129</p>	<p>130</p>	<p>131</p>	<p>132</p>
<p><b>C18.11</b></p> 	<p><b>C18.12</b></p> 	<p><b>C18.20.?</b></p> 	<p><b>C18.21</b></p> 	<p><b>C18.25</b></p> 
<p>VW/AUDI</p>	<p>VW/AUDI</p>	<p>FCA</p>	<p>FCA</p>	<p>FCA</p>
<p>Slide stop block Schieberanschlag Arresto slitta</p>	<p>Slide stop block Schieberanschlag Arresto slitta</p>	<p>Positive return plate Zwangsrückholer Gancio di sicurezza</p>	<p>Key Passfeder Chiavetta</p>	<p>Cam blank-holder guide Gleitplatte für Schieber Guida per premiamiera</p>
<p>132</p>	<p>133</p>	<p>134</p>	<p>135</p>	<p>136</p>
<p><b>C18.30</b></p> 	<p><b>C18.31</b></p> 			
<p>FORD</p>	<p>FCA</p>			
<p>Coupling plate Befestigungsplatte Staffa di reazione</p>	<p>Coupling nut Kupplungsmutter Aggancio staffa</p>			
<p>137</p>	<p>138</p>			

## GAGE HARDENED - EINWEISER GEHÄRTET - RIFERIMENTO INDURITO

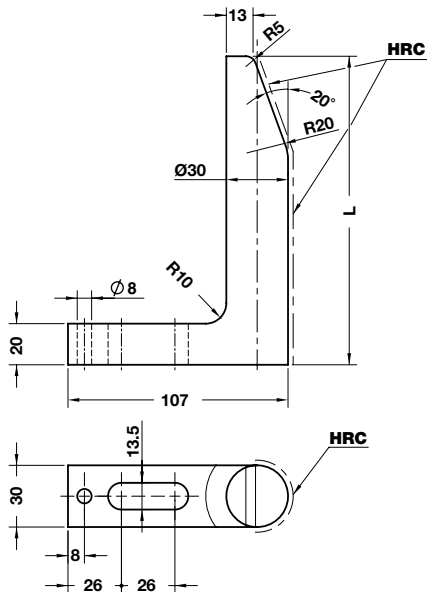

### Notes

**Material:** CK60 - HRC: 56÷60



Delivery time  
Lieferzeit in Werktagen  
Tempi di spedizione

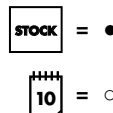

ORDER EXAMPLE	Art.	L=70
	C10.09.	070

OMCR CODE	L	Delivery Time	OMCR CODE	L	Delivery Time	OMCR CODE	L	Delivery Time
C10.09.065	65	●	C10.09.145	145	○	C10.09.225	225	○
C10.09.070	70	○	C10.09.150	150	●	C10.09.230	230	○
C10.09.075	75	○	C10.09.155	155	○	C10.09.235	235	○
C10.09.080	80	○	C10.09.160	160	○	C10.09.240	240	○
C10.09.085	85	○	C10.09.165	165	○	C10.09.245	245	○
C10.09.090	90	●	C10.09.170	170	○	C10.09.250	250	●
C10.09.095	95	○	C10.09.175	175	○	C10.09.260	260	○
C10.09.100	100	○	C10.09.180	180	●	C10.09.270	270	○
C10.09.105	105	○	C10.09.185	185	○	C10.09.280	280	○
C10.09.110	110	○	C10.09.190	190	○	C10.09.290	290	○
C10.09.115	115	○	C10.09.195	195	○	C10.09.300	300	●
C10.09.120	120	●	C10.09.200	200	○	C10.09.310	310	○
C10.09.125	125	○	C10.09.205	205	○	C10.09.320	320	○
C10.09.130	130	○	C10.09.210	210	○	C10.09.330	330	○
C10.09.135	135	○	C10.09.215	215	○	C10.09.340	340	○
C10.09.140	140	○	C10.09.220	220	○	C10.09.350	350	●



## GAGE - EINWEISER - RIFERIMENTO

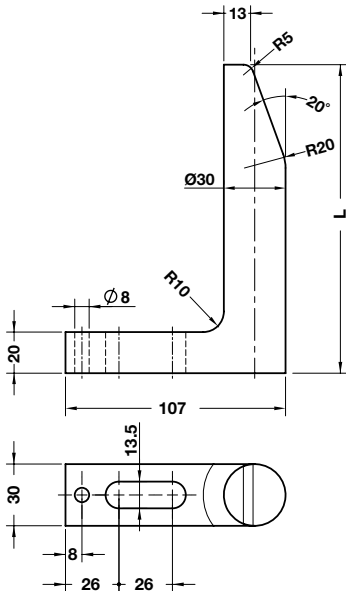

### Notes

**Material:** CK60



Standard OMCR

Delivery time  
Lieferzeit in Werktagen  
Tempi di spedizione

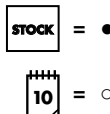

	Art.	L=70
	C10.10.	070

OMCR CODE	L	Delivery Time	OMCR CODE	L	Delivery Time	OMCR CODE	L	Delivery Time
C10.10.065	65	●	C10.10.145	145	○	C10.10.225	225	○
C10.10.070	70	○	C10.10.150	150	●	C10.10.230	230	○
C10.10.075	75	○	C10.10.155	155	○	C10.10.235	235	○
C10.10.080	80	○	C10.10.160	160	○	C10.10.240	240	○
C10.10.085	85	○	C10.10.165	165	○	C10.10.245	245	○
C10.10.090	90	●	C10.10.170	170	○	C10.10.250	250	●
C10.10.095	95	○	C10.10.175	175	○	C10.10.260	260	○
C10.10.100	100	○	C10.10.180	180	●	C10.10.270	270	○
C10.10.105	105	○	C10.10.185	185	○	C10.10.280	280	○
C10.10.110	110	○	C10.10.190	190	○	C10.10.290	290	○
C10.10.115	115	○	C10.10.195	195	○	C10.10.300	300	●
C10.10.120	120	●	C10.10.200	200	○	C10.10.310	310	○
C10.10.125	125	○	C10.10.205	205	○	C10.10.320	320	○
C10.10.130	130	○	C10.10.210	210	○	C10.10.330	330	○
C10.10.135	135	○	C10.10.215	215	○	C10.10.340	340	○
C10.10.140	140	○	C10.10.220	220	○	C10.10.350	350	●

## GAGE FOR SENSOR - EINWEISER FÜR TEILLAGEKONTROLLE - RIFERIMENTO PER SENSORE

**Notes**

**1** Material: CK60  
HRC: 50±55

**2** Material: Si37

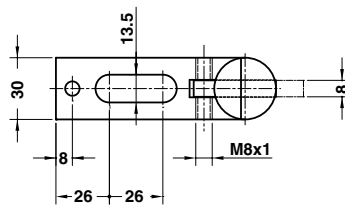
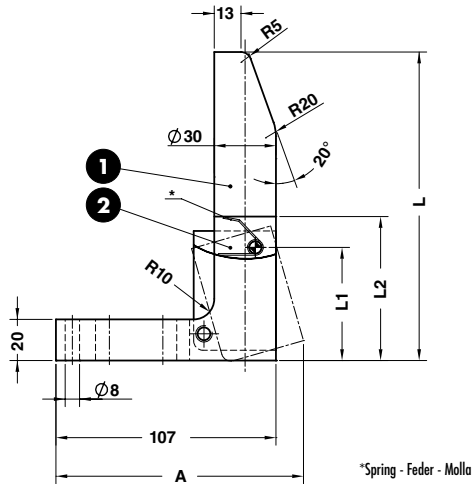
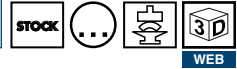
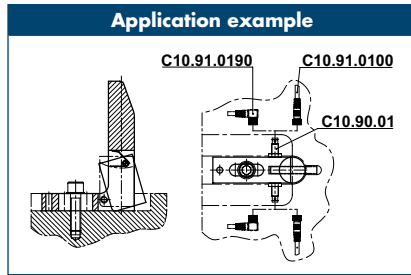

	Art.	L=180
	C10.11.	180

OMCR CODE	A	L	L1	L2
C10.11.120	120	120	55	70
C10.11.150	120	150	55	70
C10.11.180	124	180	105	120
C10.11.250	124	250	105	120

## GAGE - EINWEISER - RIFERIMENTO

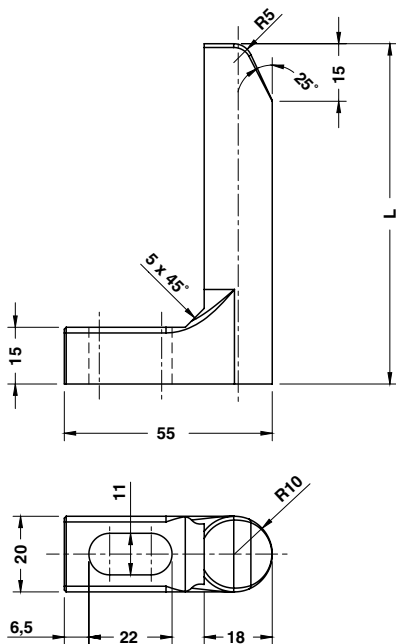

WEB

### Notes

**Material:** CK45



Art.	L=90
C10.12.	090

OMCR CODE	L
C10.12.055	55
C10.12.065	65
C10.12.090	90
C10.12.095	95
C10.12.120	120

Standard OMCR

## GAGE HARDENED - EINWEISER GEHÄRTET - RIFERIMENTO INDURITO

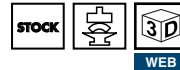
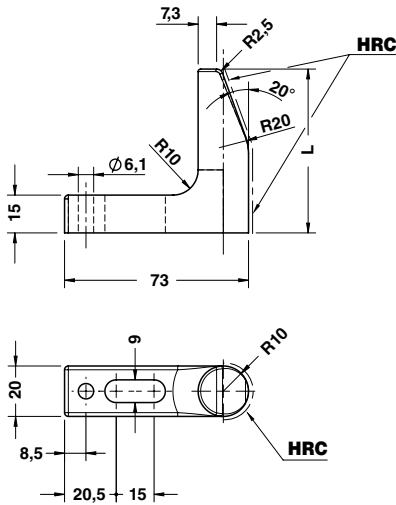

**Notes**  
**Material:** CK60 - HRC: 58÷60

ORDER EXAMPLE	Art.	L=65
	C10.13.	065

OMCR CODE	L
C10.13.065	65
C10.13.090	90

## GAGE - EINWEISER - RIFERIMENTO

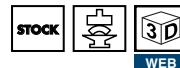
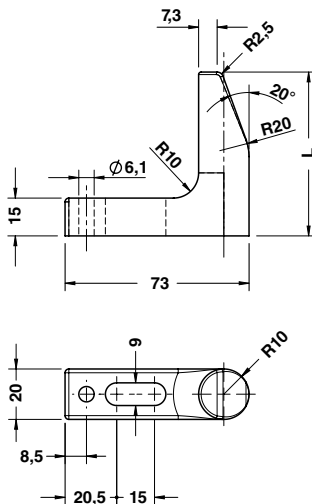

**Notes**  
**Material:** CK60

ORDER EXAMPLE	Art.	L=65
	C10.14.	065

OMCR CODE	L
C10.14.065	65
C10.14.090	90

## GAGE FOR SENSOR - EINWEISER FÜR TEILLAGEKONTROLLE - RIFERIMENTO PER SENSORE

### Notes

**1**

**Material:** CK60

**2**

**Material:** S137 - HRC: 58÷60

### Application example

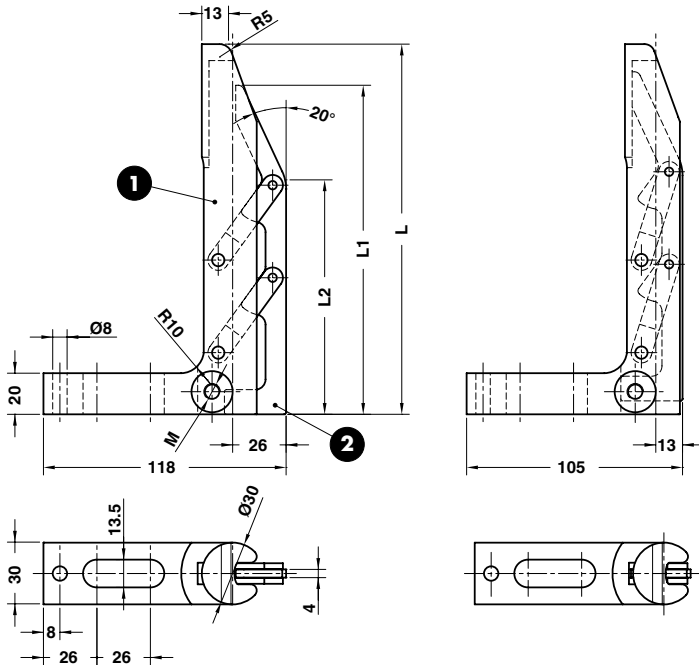
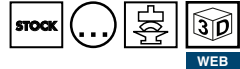
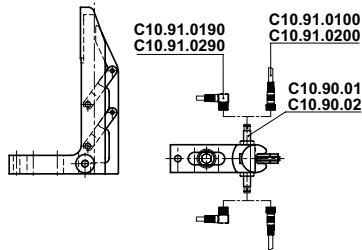

Art.	L=120	L1=113	M=8x1
C10.15.	120	113	08

OMCR CODE	L	L1	L2	M
C10.15.12011308	120	113	78	8x1
C10.15.12011312	120	113	78	12x1
C10.15.15013008	150	130	90	8x1
C10.15.15013012	150	130	90	12x1
C10.15.18016008	180	160	114	8x1
C10.15.18016012	180	160	114	12x1
C10.15.25016008	250	160	114	8x1
C10.15.25016012	250	160	114	12x1
C10.15.25023008	250	230	184	8x1
C10.15.25023012	250	230	184	12x1

## PRECISION GAGE - FEINENWEISER - RIFERIMENTO DI PRECISIONE

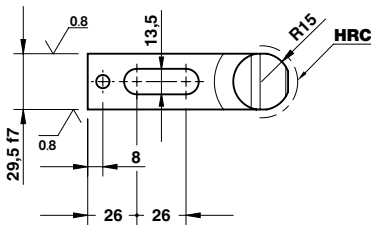
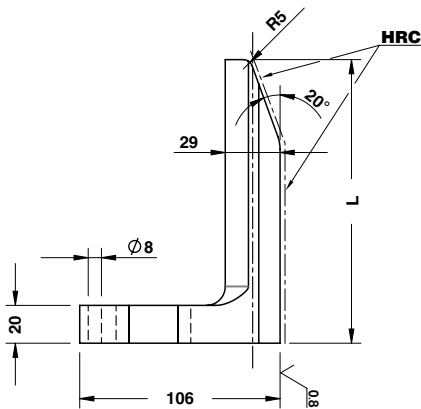

### Notes

**Material:** CK60 - HRC: 58÷60



WEB

Delivery time  
Lieferzeit in Werktagen  
Tempi di spedizione

**STOCK** = ●

**15** = ○

	Art.	L=70
	C10.16.	070

OMCR CODE	L	Delivery Time	OMCR CODE	L	Delivery Time	OMCR CODE	L	Delivery Time
C10.16.065	65	●	C10.16.145	145	○	C10.16.225	225	○
C10.16.070	70	○	C10.16.150	150	●	C10.16.230	230	○
C10.16.075	75	○	C10.16.155	155	○	C10.16.235	235	○
C10.16.080	80	○	C10.16.160	160	○	C10.16.240	240	○
C10.16.085	85	○	C10.16.165	165	○	C10.16.245	245	○
C10.16.090	90	●	C10.16.170	170	○	C10.16.250	250	●
C10.16.095	95	○	C10.16.175	175	○	C10.16.260	260	○
C10.16.100	100	○	C10.16.180	180	●	C10.16.270	270	○
C10.16.105	105	○	C10.16.185	185	○	C10.16.280	280	○
C10.16.110	110	○	C10.16.190	190	○	C10.16.290	290	○
C10.16.115	115	○	C10.16.195	195	○	C10.16.300	300	●
C10.16.120	120	●	C10.16.200	200	○	C10.16.310	310	○
C10.16.125	125	○	C10.16.205	205	○	C10.16.320	320	○
C10.16.130	130	○	C10.16.210	210	○	C10.16.330	330	○
C10.16.135	135	○	C10.16.215	215	○	C10.16.340	340	○
C10.16.140	140	○	C10.16.220	220	○	C10.16.350	350	●



GAGE - EINWEISER - RIFERIMENTO

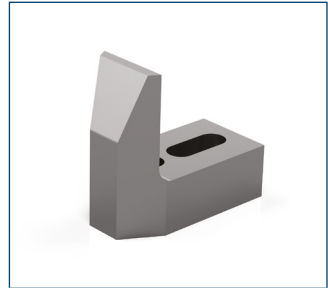
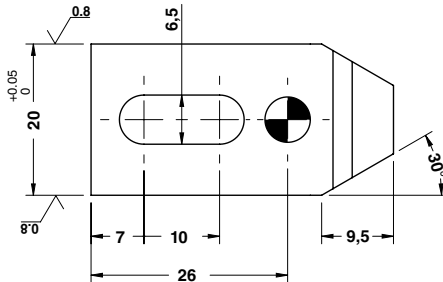
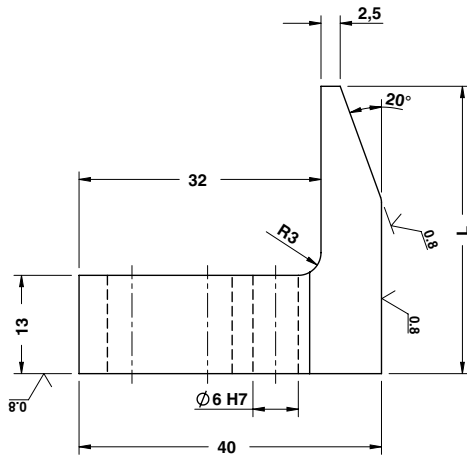

**Notes**  
**Material:** 21MnCr5 - **HRC:** 58÷60

ORDER EXAMPLE	Art.	L=38
	C10.18.	038

OMCR CODE	L
C10.18.028	28
C10.18.038	38
C10.18.048	48
C10.18.058	58
C10.18.068	68
C10.18.078	78
C10.18.088	88

Standard OMCR

## FRONT GAGE - EINLAUFANSCHLAG - PORTASENSORE

### Notes

**Material:** St37

### Application example

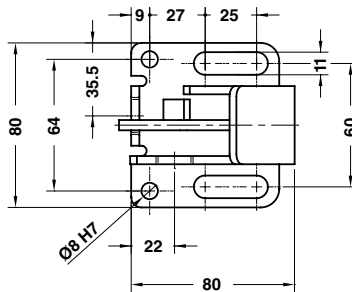
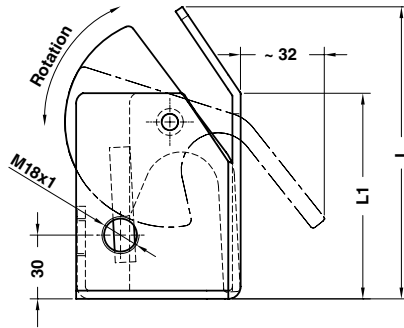
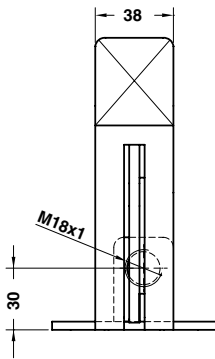
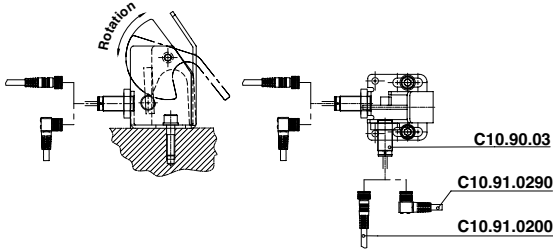

ORDER EXAMPLE	Art.	L=142
	C10.20.	142

OMCR CODE	L	L1
C10.20.117	117	75
C10.20.142	142	100
C10.20.192	192	150

## SUPPORT FOR SENSOR - LAGEKONTROLLE FÜR PLATINEN - SUPPORTO SENSORE

<b>Notes</b> <b>Material:</b> Steel	<b>Application example</b> 	

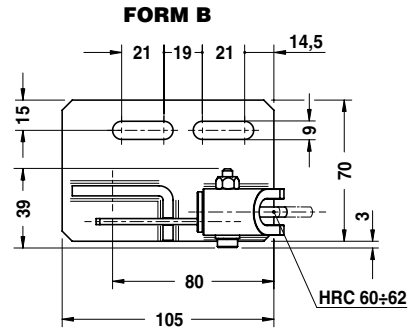
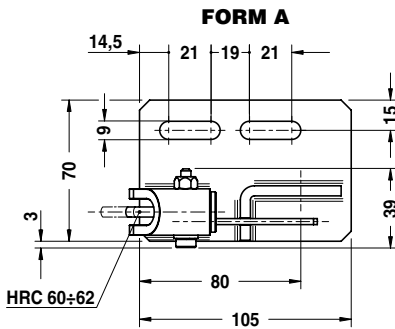
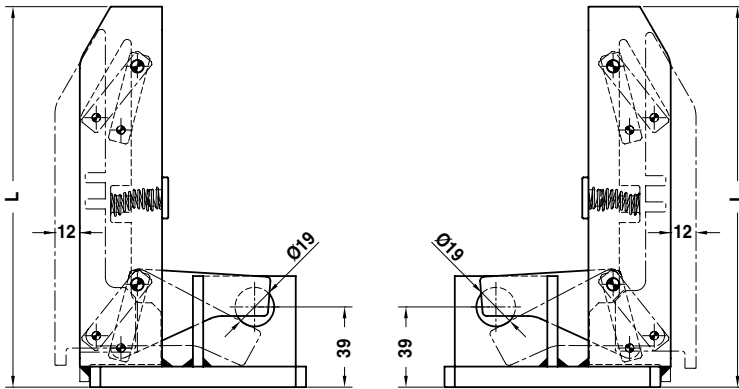

Standard OMCR



ORDER EXAMPLE	Art.	TYPE
	C10.25.	01

OMCR CODE	TYPE	L	FORM
C10.25.01	01	145	A
C10.25.02	02	145	B
C10.25.03	03	185	A
C10.25.04	04	185	B
C10.25.25	25	225	A
C10.25.26	26	225	B

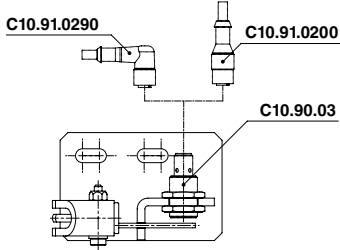
## SUPPORT FOR SENSOR - LAGEKONTROLLE FÜR PLATINEN - SUPPORTO SENSORE

<b>Notes</b>	<b>Application example</b>	
<b>Material:</b> Steel		
		 

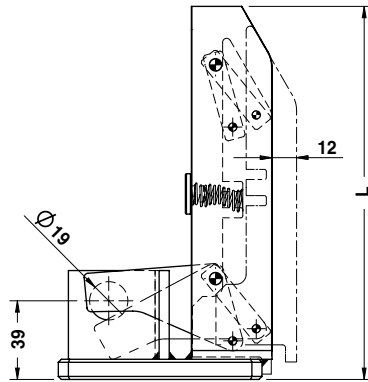
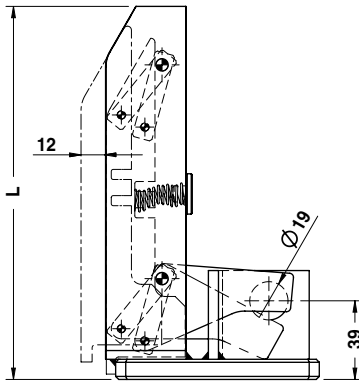

**FORM A**

**FORM B**

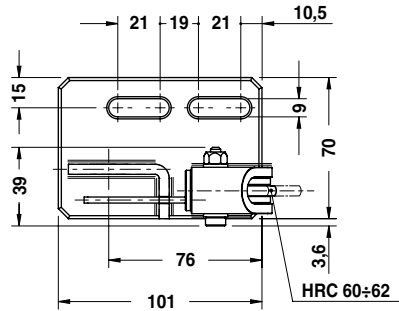
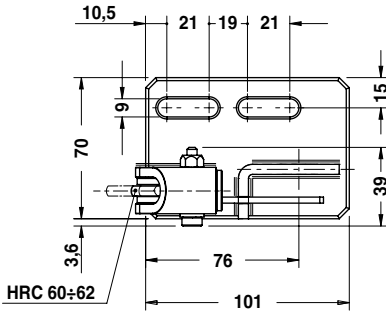

	Art.	TYPE
	C10.25.	30

OMCR CODE	TYPE	L	FORM
C10.25.30	30	145	A
C10.25.31	31	145	B
C10.25.32	32	185	A
C10.25.33	33	185	B
C10.25.34	34	225	A
C10.25.35	35	225	B

## GAGE - EINWEISER - RIFERIMENTO

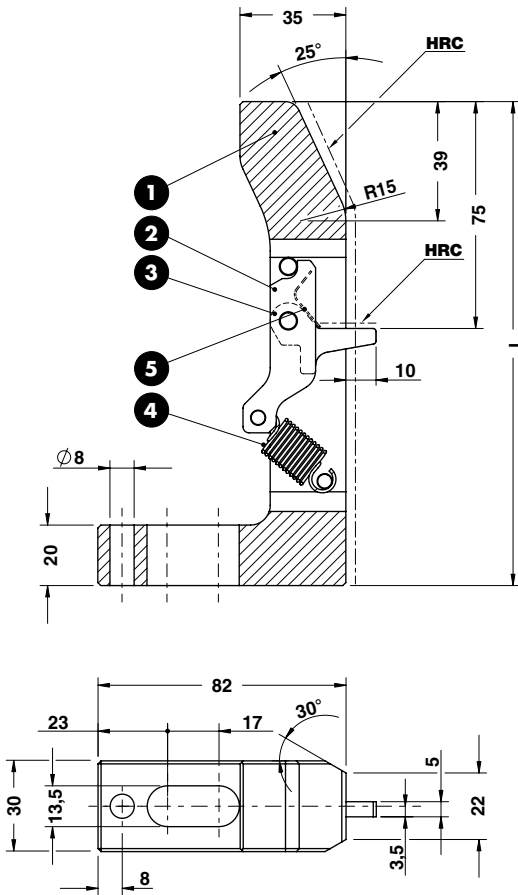

### Notes

- 1 3** Material: CK45 - HRC: 58±60
- 2** Material: CK45 - HRC: 54±56
- 4** Spring
- 5** Spring

ORDER EXAMPLE	Art.	L=180	F1=5,9
	C10.30.	180	05

OMCR CODE	L	F1(N)	F2(N)
C10.30.16005	160	5,9	18,5
C10.30.16010	160	10	30
C10.30.16022	160	22	65
C10.30.17005	170	5,9	18,5
C10.30.17010	170	10	30
C10.30.17022	170	22	65
C10.30.18005	180	5,9	18,5
C10.30.18010	180	10	30
C10.30.18022	180	22	65
C10.30.19005	190	5,9	18,5
C10.30.19010	190	10	30
C10.30.19022	190	22	65
C10.30.20005	200	5,9	18,5
C10.30.20010	200	10	30
C10.30.20022	200	22	65

### Application example

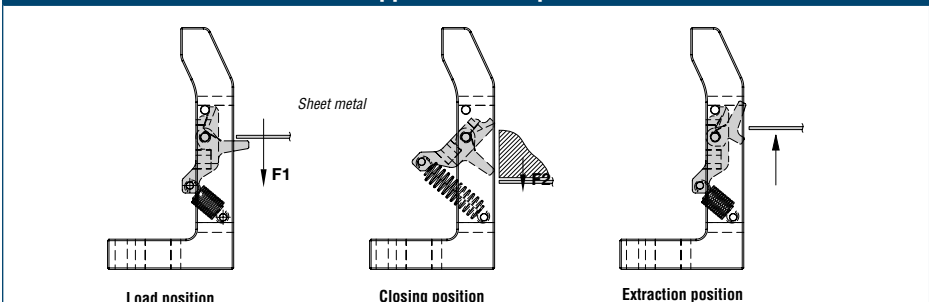

## SENSOR - INDUKTIVE SENSOR - SENSORE

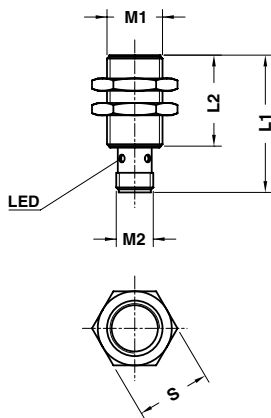

### Notes

Manufactured by  
 Hersteller - Costruttore: **BALLUFF**

### Application example

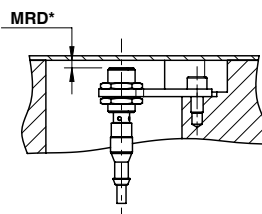

\*Max reading distance  
 Maximale Lesereichweite  
 Distanza massima di lettura

ORDER EXAMPLE	Art.
	<b>C10.90.01</b>

OMCR CODE	L1	L2	M1	M2	S	MRD* on steel (mm)	MRD* on aluminium (mm)
C10.90.01	30	23,5	M8x1	M8x1	13	1,5	-
C10.90.02	45	30	M12x1	M12x1	17	4	-
C10.90.03	44,5	29,5	M18x1	M12x1	24	5	3
C10.90.04	44,5	30	M30x1,5	M12x1	36	10	6

TECHNICAL DATA	C10.90.01	C10.90.02	C10.90.03	C10.90.04
1 Rated operational voltage (Ue)	24 V DC	24 V DC	24 V DC	24 V DC
2 Supply voltage (Ub)	10...30 V DC	10...30 V DC	10...30 V DC	10...30 V DC
3 No load supply current (I <sub>o max.</sub> )	≤ 7 mA	≤ 10 mA	≤ 10 mA	≤ 25 mA
4 Residual current (I <sub>r</sub> )	≤ 10 µA	≤ 50 µA	≤ 50 µA	≤ 80 µA
5 Repeat accuracy (R)	≤ 5 %	≤ 5 %	≤ 5 %	≤ 5 %
6 Ambient temperature range (Ta)	-40...+85° C	-25...+85° C	-25...+70° C	-25...+70° C
7 Frequency of operating cycles (f)	5000 Hz	2000 Hz	1000 Hz	150 Hz
8 Degree of protection per IEC 60529	IP 68	IP 68	IP 67	IP 67
9 Housing material	Stainless Steel	Stainless Steel	Brass	Brass
10 Connection	Connector	Connector	Connector	Connector
11 Approval	CE/UL	CE/UL	CE/UL	CE/UL
12 Switching output	PNP normally open	PNP normally open	PNP normally open	PNP normally open



## CONNECTOR - STECKVERBINDER - CONNETTORE

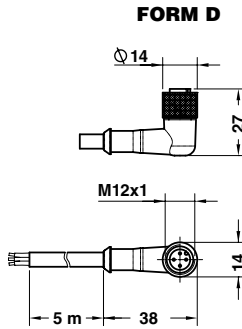
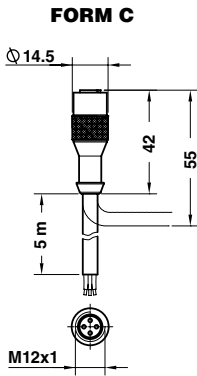
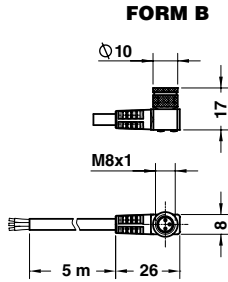
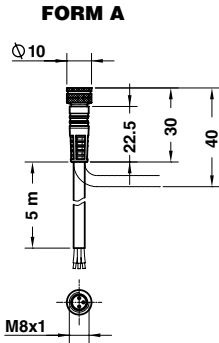

### Notes

Manufactured by  
Hersteller - Costruttore: **BALLUFF**

ORDER EXAMPLE 	Art.
	C10.91.0190

OMCR CODE	FORM
C10.91.0100	A
C10.91.0190	B
C10.91.0200	C
C10.91.0290	D

## SENSOR - INDUKTIVE SENSOR - SENSORE

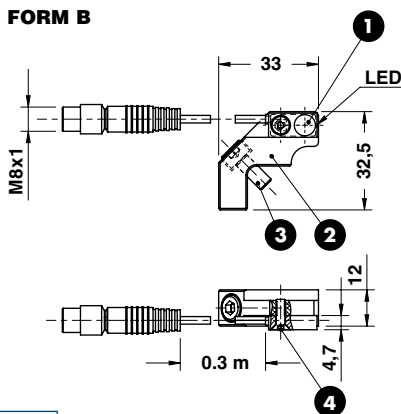
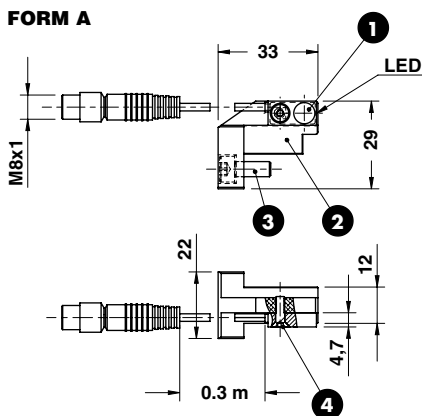

### Notes

- 1 Manufactured by  
Hersteller - Costruttore: **BALLUFF**
- 2 Aluminium
- 3 M5x12 DIN 912
- 4 M3x10 DIN 7991

### Application example

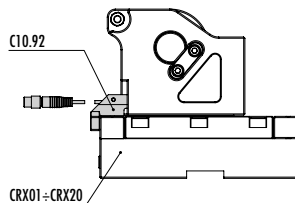

\* Max reading distance  
 Maximale Lesereichweite  
 Distanza massima di lettura

ORDER EXAMPLE	Art.
	C10.92.01

OMCR CODE	Form	MRD* on steel (mm)	Using with cam units
C10.92.01	A	2	CRX01
C10.92.02	B	2	CRX03, CRX05, CRX15, CRX20

### SENSOR TECHNICAL DATA

1 Rated operational voltage (Ue)	24 V DC
2 Supply voltage (Ub)	10...30 V DC
3 No load supply current (I <sub>o max.</sub> )	≤ 10 mA
4 Residual current (I <sub>r</sub> )	≤ 50 μA
5 Repeat accuracy (R)	≤ 1 %
6 Ambient temperature range (T <sub>a</sub> )	-25...+70° C
7 Frequency of operating cycles (f)	5000 Hz
8 Degree of protection per IEC 60529	IP 67
9 Housing material	Brass
10 Connection	Cable with connector, 0.30 m
11 Approval	CE/UL
12 Switching output	PNP normally open

PLATE FOR SENSOR - HALTERUNG - PIASTRINA PORTASENSORE

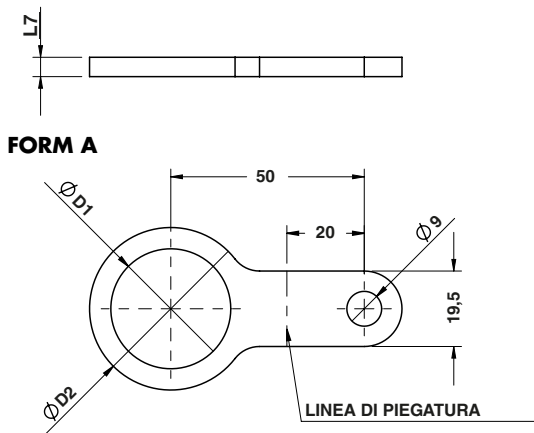

**Notes**  
**Material:** S137

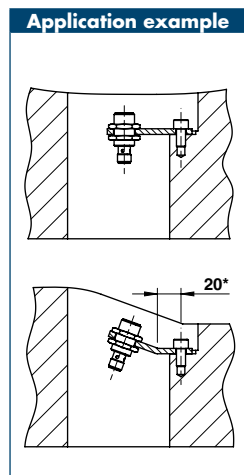
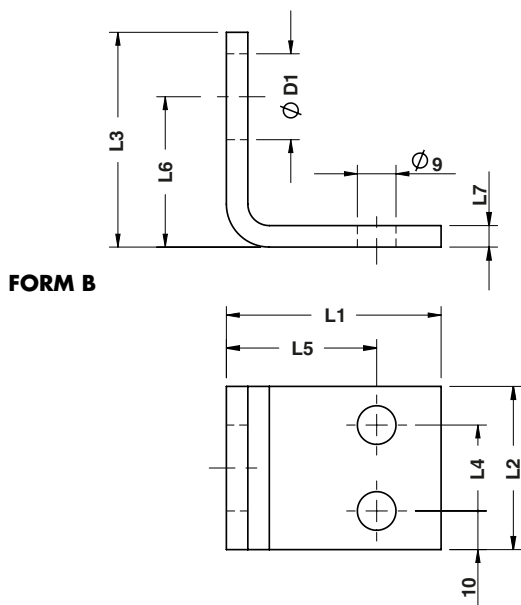

\* Biegekante  
 Edge bending  
 Linea di piegatura

ORDER EXAMPLE  
 Art. C10.95.03

OMCR CODE	L1	L2	L3	L4	L5	L6	L7	D1	D2	FORM	Using with sensor
C10.95.01	-	-	-	-	-	-	5	19	30	A	C10.90.03
C10.95.02	-	-	-	-	-	-	5	31	42	A	C10.90.04
C10.95.03	80	50	60	30	60	35	7	19	-	B	C10.90.03
C10.95.04	80	50	60	30	60	35	7	31	-	B	C10.90.04
C10.95.05	40	40	80	20	25	-	6	-	-	B	-

Standard OMCR

LOCATING CONE - KEGELDISTANZ - CONO DI CENTRAGGIO

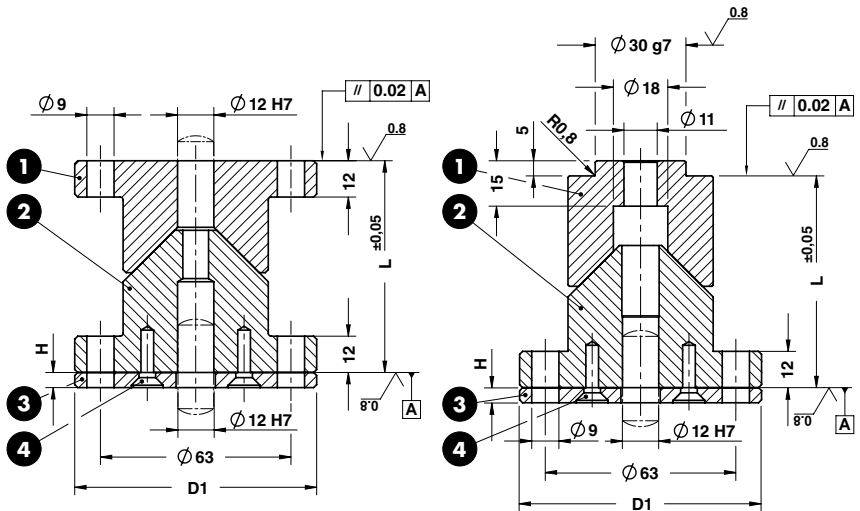

FORM A

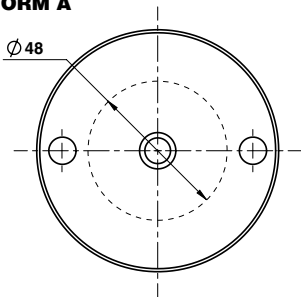

FORM C

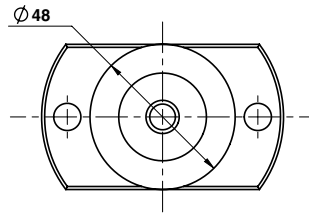

FORM B

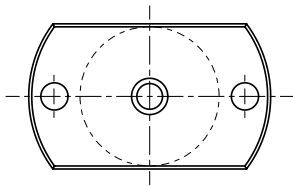

## LOCATING CONE - KEGELDISTANZ - CONO DI CENTRAGGIO

### Notes

- 1 2** Material: 16MnCr5 - HRC: 60÷62
- 3** Material: CK45
- 4** M5x12 DIN 7991



Standard OMCR

ORDER EXAMPLE	Art.	D1=80	L=70	FORM	TYPE
	C11.08.	80	70	A	01

OMCR CODE	D1	L	H	FORM	TYPE
C11.08.08070A00	80	70	5	A	00
C11.08.08070A01	80	70	5,5	A	01
C11.08.08070B00	80	70	5	B	00
C11.08.08070B01	80	70	5,5	B	01
C11.08.08070C00	80	70	5	C	00
C11.08.08070C01	80	70	5,5	C	01

## LOCATING CONE - KEGELDISTANZ - CONO DI CENTRAGGIO

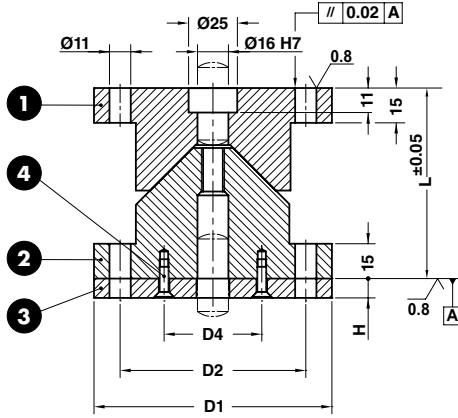
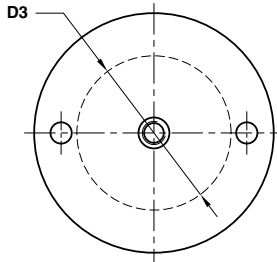
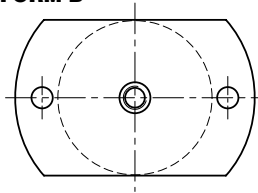
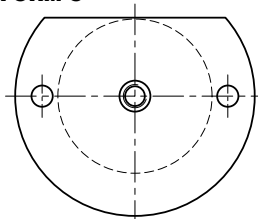
**FORM A****FORM B****FORM C**



## LOCATING CONE - KEGELDISTANZ - CONO DI CENTRAGGIO

### Notes

- 1 2** Material: 16MnCr5 - HRC: 60÷62
- 3** Material: CK45
- 4** M5x16 DIN 7991

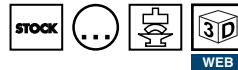

Standard OMCR

ORDER EXAMPLE	Art.	D1=100	L=80	FORM	TYPE
	C11.09.	100	80	B	01

OMCR CODE	D1	D2	D3	D4	L	H	FORM	TYPE
C11.09.10080A00	100	76	58	40,5	80	10,5	A	00
C11.09.10080A01	100	76	58	40,5	80	10	A	01
C11.09.10080B00	100	76	58	40,5	80	10,5	B	00
C11.09.10080B01	100	76	58	40,5	80	10	B	01
C11.09.10080C00	100	76	58	40,5	80	10,5	C	00
C11.09.10080C01	100	76	58	40,5	80	10	C	01
C11.09.12090A00	120	96	78	50,5	90	10,5	A	00
C11.09.12090A01	120	96	78	50,5	90	10	A	01
C11.09.12090B00	120	96	78	50,5	90	10,5	B	00
C11.09.12090B01	120	96	78	50,5	90	10	B	01
C11.09.12090C00	120	96	78	50,5	90	10,5	C	00
C11.09.12090C01	120	96	78	50,5	90	10	C	01

LOCATING CONE - KEGELDISTANZ - CONO DI CENTRAGGIO

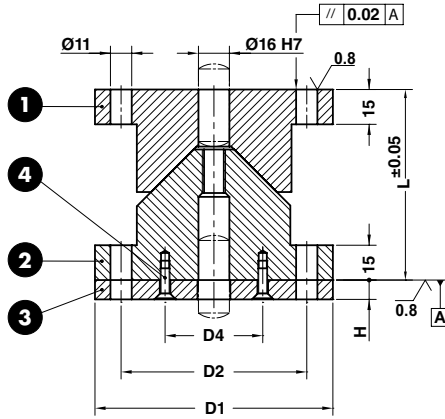

"FORM A"

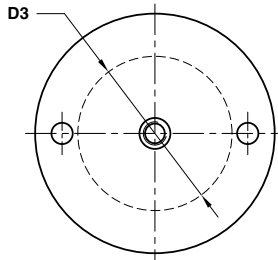

"FORM B"

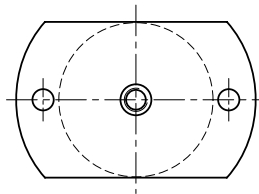

"FORM C"

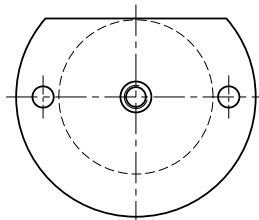

## LOCATING CONE - KEGELDISTANZ - CONO DI CENTRAGGIO

### Notes

- 1 2** Material: 16MnCr5 - HRC: 60÷62
- 3** Material: CK45
- 4** M5x16 DIN 7991



Standard OMCR

	Art.	D1=100	L=80	FORM	TYPE
	C11.11.	100	80	B	01

OMCR CODE	D1	D2	D3	D4	L	H	FORM	TYPE
C11.11.10080A00	100	76	58	40,5	80	10,5	A	00
C11.11.10080A01	100	76	58	40,5	80	10	A	01
C11.11.10080A02	100	76	58	40,5	80	5,5	A	02
C11.11.10080A03	100	76	58	40,5	80	5	A	03
C11.11.10080B00	100	76	58	40,5	80	10,5	B	00
C11.11.10080B01	100	76	58	40,5	80	10	B	01
C11.11.10080B02	100	76	58	40,5	80	5,5	B	02
C11.11.10080B03	100	76	58	40,5	80	5	B	03
C11.11.10080C00	100	76	58	40,5	80	10,5	C	00
C11.11.10080C01	100	76	58	40,5	80	10	C	01
C11.11.10080C02	100	76	58	40,5	80	5,5	C	02
C11.11.10080C03	100	76	58	40,5	80	5	C	03
C11.11.12090A00	120	96	78	50,5	90	10,5	A	00
C11.11.12090A01	120	96	78	50,5	90	10	A	01
C11.11.12090A02	120	96	78	50,5	90	5,5	A	02
C11.11.12090A03	120	96	78	50,5	90	5	A	03
C11.11.12090B00	120	96	78	50,5	90	10,5	B	00
C11.11.12090B01	120	96	78	50,5	90	10	B	01
C11.11.12090B02	120	96	78	50,5	90	5,5	B	02
C11.11.12090B03	120	96	78	50,5	90	5	B	03
C11.11.12090C00	120	96	78	50,5	90	10,5	C	00
C11.11.12090C01	120	96	78	50,5	90	10	C	01
C11.11.12090C02	120	96	78	50,5	90	5,5	C	02
C11.11.12090C03	120	96	78	50,5	90	5	C	03

## LOCATING PIN - ZENTRIERBOLZEN - PERNO DI CENTRAGGIO

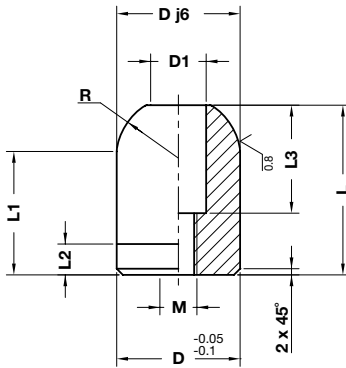

### Notes

**Material:** 16MnCr5 - **HRC:** 58±60

### Application example

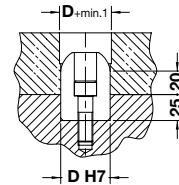

Art.	D=22	L=45
C11.12.	22	45

OMCR CODE	D	D1	L	L1	L2	L3	M	R
C11.12.2245	22	14	45	37,5	8	25	10	12,5
C11.12.3250	32	18	50	40	10	35	12	20
C11.12.4055	40	18	55	40	10	35	12	20
C11.12.5055	50	18	55	40	10	35	12	20

# C11.15

## LOCATING PIN - ZENTRIERBOLZEN - PERNO DI CENTRAGGIO

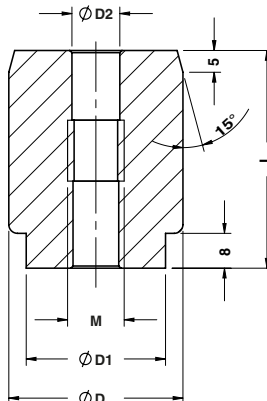

### Notes

**Material:** 16MnCr5 - **HRC:** 58±60



Art.	D=32	L=50
C11.15.	32	50

OMCR CODE	D	D1	D2	L	M
C11.15.2550	25	18	11	50	M8
C11.15.3250	32	25	11	50	M8
C11.15.4050	40	32	15	50	M10
C11.15.5050	50	42	15	50	M10

## LOCATING PIN - ZENTRIERBOLZEN - PERNO DI CENTRAGGIO

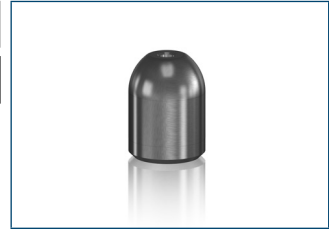
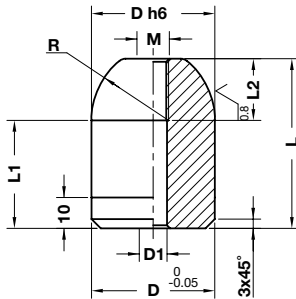

### Notes

**Material:** 16MnCr5 - **HRC:** 58÷60

Standard OMCR

	Art.	D=22	L=45
	C11.20.	22	45

OMCR CODE	D	D1	L	L1	L2	M	R
C11.20.2245	22	7	45	35	16	M8	15
C11.20.2255	22	7	55	45	16	M8	15
C11.20.3250	32	9	50	37,5	20	M10	20
C11.20.4055	40	9	55	35	20	M10	25
C11.20.4065	40	9	65	45	20	M10	25
C11.20.4085	40	9	85	65	20	M10	25
C11.20.5055	50	9	55	41,25	20	M10	25
C11.20.5680	56	9	80	60	20	M10	30

**VISUAL LOCATOR SETTING PUNCH - ENDKONTROLLSTEMPEL - PUNZONE DI VISUALIZZAZIONE**

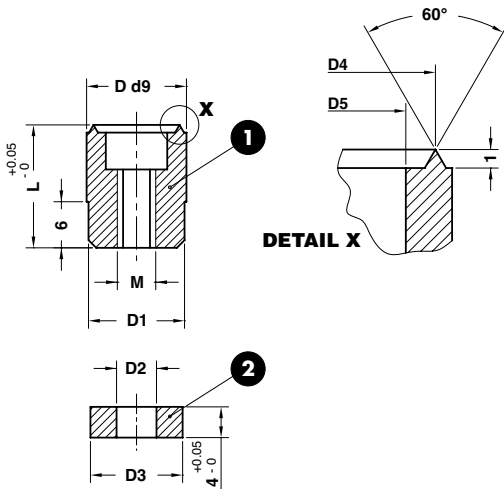

Notes	
1	Material: X205Cr12KU HRC: 60÷62
2	Material: X205Cr12KU

ORDER EXAMPLE	Art.	D=10	L=16
	C11.30.	10	16

OMCR CODE	D	D1	D2	D3	D4	D5	L	M
C11.30.1016	10	9,5	4,2	9,7	8	6	16	M4
C11.30.1316	13	12,5	5,2	12	11,2	8	16	M5

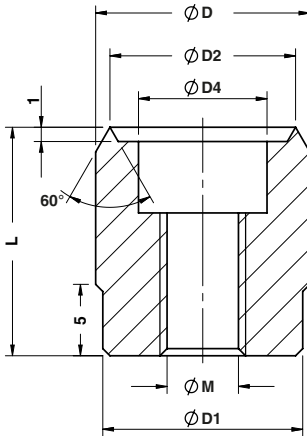

**Notes**

**Material:** X155CrVNo121  
**HRC:** 58÷60

Standard OMCR

ORDER EXAMPLE	Art.	D=18	L=16
	C11.31.	18	16

OMCR CODE	D	D1	D2	D3	D4	L	M
C11.31.1316	13	12	11,8	5	8	16	M6
C11.31.1516	15	14	13	5	9	16	M6
C11.31.1816	18	17,5	16	7	11	16	M8
C11.31.2116	21	20,5	19	9	14	16	M10

## ADJUSTMENT PLATE - SCHEIBE - RONDELLA DI REGISTRO

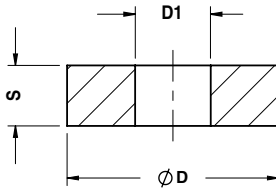
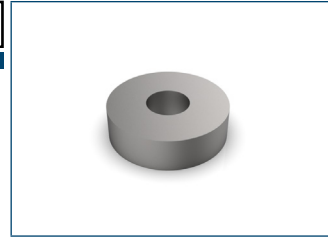

### Notes

**Material:** 42CrMo4

ORDER EXAMPLE	Art.	D=17,5	S=4
		C11.32.	175
OMCR CODE	D	D1	S
C11.32.1203	12	5	3
C11.32.1404	14	5	4
C11.32.1754	17.5	7	4
C11.32.2054	20.5	9	4

## VISUAL LOCATOR SETTING PUNCH - ENDKONTROLLSTEMPEL - PUNZONE DI VISUALIZZAZIONE

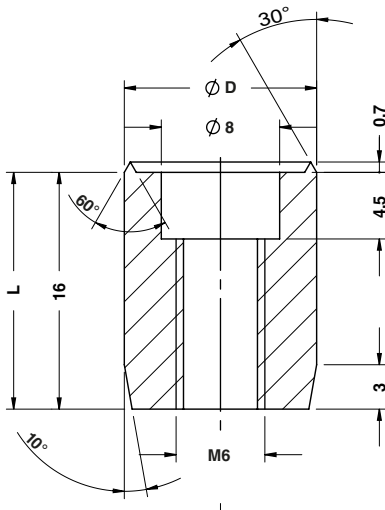

### Notes

**Material:** X210Cr12 - HRC: 60-62

ORDER EXAMPLE	Art.	D=13	L=16,7
		C11.33.	13
OMCR CODE	D	L	
C11.33.13167	13	16,7	



## STAMP RETAINER - HALTEPLATTE - PORTATIMBRI

### Notes

1 2

Material: CK45

3

ELASTIC PIN  $\varnothing 2.5 \times 14$  DIN 1481

### Application example

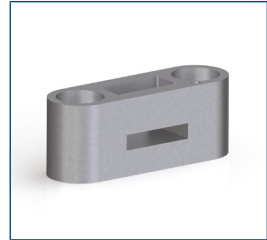
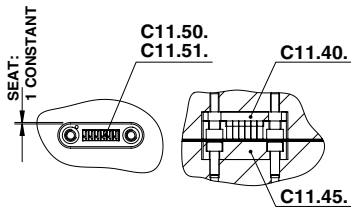

Standard OMCR

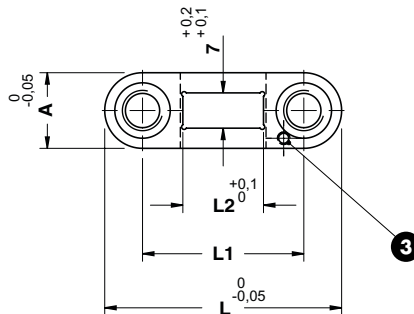
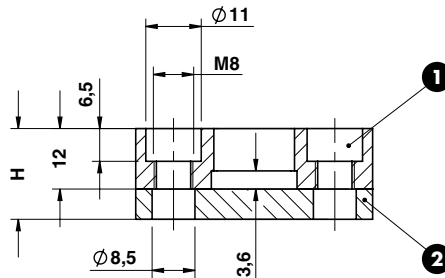

Art.	A=15	H=18	L=47
C11.40.	15	18	047

OMCR CODE	A	H	L	L1	L2	Nr. of stamps C11.50.	Nr. of stamps C11.51.
C11.40.1518045	15	18	45	30	12	3	6
C11.40.1518047	15	18	47	32	16	4	8
C11.40.1518055	15	18	55	40	24	6	12
C11.40.1518063	15	18	63	48	32	8	16
C11.40.1518071	15	18	71	56	40	10	20

## BACKING PLATE - DRUCKPLATTE - REAZIONE

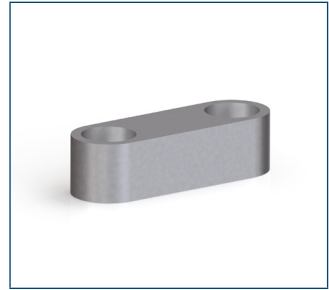
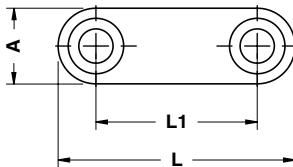
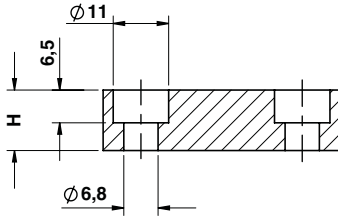

### Notes

**Material:** CK45

ORDER EXAMPLE	Art.	A=15	H=12	L=47
	C11.45.	15	12	047

OMCR CODE	A	H	L	L1	Used with Stamp Retainer
C11.45.1512045	15	12	45	30	C11.40.1518045
C11.45.1512047	15	12	47	32	C11.40.1518047
C11.45.1512055	15	12	55	40	C11.40.1518055
C11.45.1512063	15	12	63	48	C11.40.1518063
C11.45.1512071	15	12	71	56	C11.40.1518071

## STAMP - BUCHSTABENSTEMPEL - PUNZONE MARCHIO

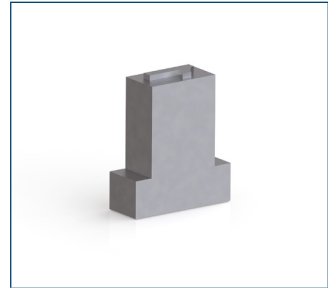
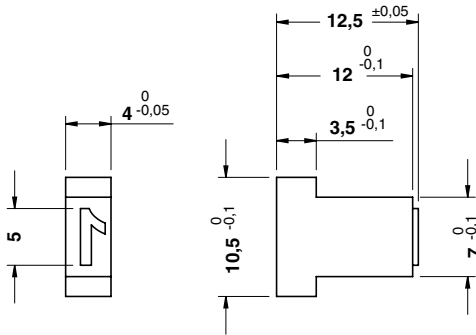

### Notes

**Material:** X153CrMoV12  
**HRC:** 54÷56

Standard OMCR

ORDER EXAMPLE	Art.
	C11.50.01

OMCR CODE	Stamp	OMCR CODE	Stamp	OMCR CODE	Stamp	OMCR CODE	Stamp
C11.50.00	0	C11.50.10	B	C11.50.20	L	C11.50.30	V
C11.50.01	1	C11.50.11	C	C11.50.21	M	C11.50.31	W
C11.50.02	2	C11.50.12	D	C11.50.22	N	C11.50.32	X
C11.50.03	3	C11.50.13	E	C11.50.23	O	C11.50.33	Y
C11.50.04	4	C11.50.14	F	C11.50.24	P	C11.50.34	Z
C11.50.05	5	C11.50.15	G	C11.50.25	Q	C11.50.35	SPACE
C11.50.06	6 or 9	C11.50.16	H	C11.50.26	R	C11.50.36	-
C11.50.07	7	C11.50.17	I	C11.50.27	S	C11.50.37	-
C11.50.08	8	C11.50.18	J	C11.50.28	T		
C11.50.09	A	C11.50.19	K	C11.50.29	U		

## STAMP - BUCHSTABENSTEMPEL - PUNZONE MARCHIO

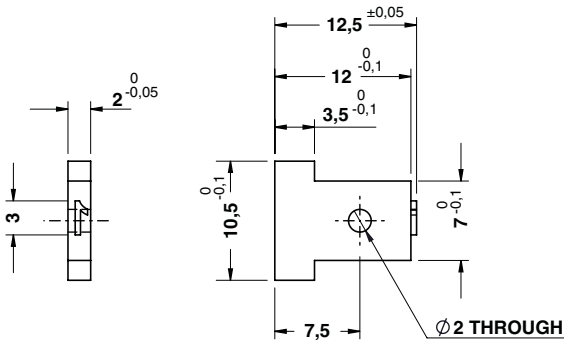

### Notes

**Material:** X153CrMoV12

**HRC:** 54÷56

ORDER EXAMPLE	Art.
	C11.51.01

OMCR CODE	Stamp	OMCR CODE	Stamp	OMCR CODE	Stamp	OMCR CODE	Stamp
C11.51.00	0	C11.51.10	B	C11.51.20	L	C11.51.30	V
C11.51.01	1	C11.51.11	C	C11.51.21	M	C11.51.31	W
C11.51.02	2	C11.51.12	D	C11.51.22	N	C11.51.32	X
C11.51.03	3	C11.51.13	E	C11.51.23	O	C11.51.33	Y
C11.51.04	4	C11.51.14	F	C11.51.24	P	C11.51.34	Z
C11.51.05	5	C11.51.15	G	C11.51.25	Q	C11.51.35	SPACE
C11.51.06	6 or 9	C11.51.16	H	C11.51.26	R	C11.51.36	-
C11.51.07	7	C11.51.17	I	C11.51.27	S	C11.51.37	-
C11.51.08	8	C11.51.18	J	C11.51.28	T		
C11.51.09	A	C11.51.19	K	C11.51.29	U		

## AIR PIN - DRUCKBOLZEN - CANDELA

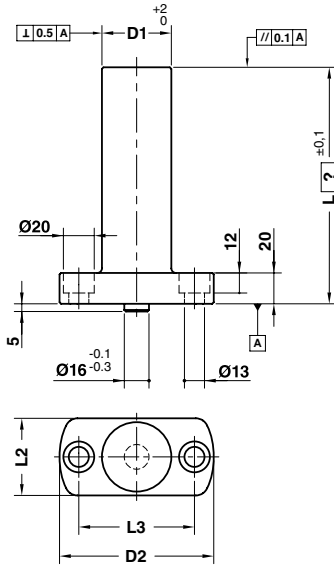

$L_{max} = 360 \text{ mm}$

Respect the max. load  
 Maximale Nutzlast beachten  
 Rispettare il carico max.

**Notes**

**Material:** CK45 - 800÷1000 N/mm<sup>2</sup>

	Art.	D1=36	L=230
	C12.10.	36	230

OMCR CODE	D1	D2	L2	L3	Max load (kN)
C12.10.	36	90	40	65	50
C12.10.	45	100	50	75	70

Standard OMCR

AIR PIN - UNTERLUFTBOLZEN - CANDELA

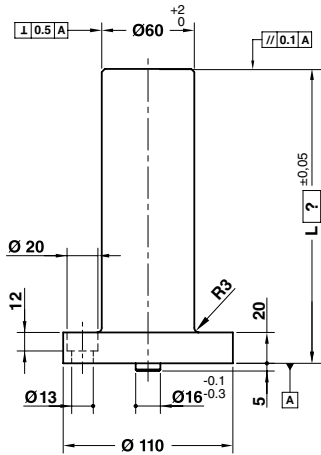

TYPE 01

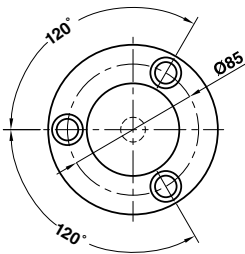

TYPE 02

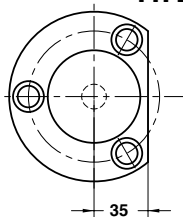

**L<sub>max</sub> = 450 mm**  
 Respect the max. load  
 Maximale Nutzlast beachten  
 Rispettare il carico max.

**Notes**  
**Material:** CK45 - 800÷1000 N/mm<sup>2</sup>

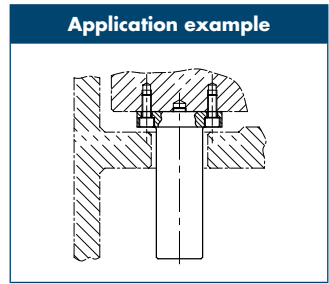

ORDER EXAMPLE	Art.	TYPE	L=220
	C12.11.	01	220
<b>OMCR CODE</b>		<b>TYPE</b>	<b>Max Load (kN)</b>
C12.11.		01	80
C12.11.		02	80

AIR PIN - UNTERLUFTBOLZEN - CANDELA

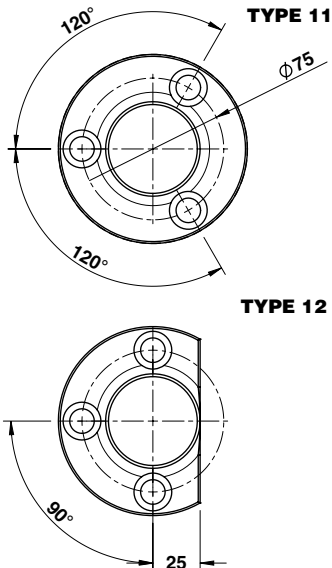
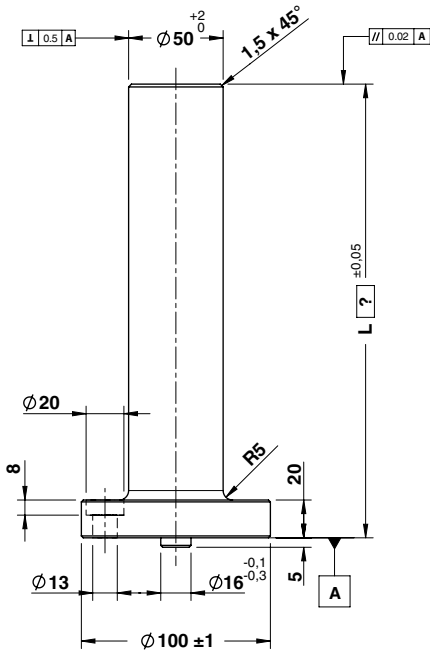

Standard OMCR



**Lmax = 450 mm**  
 Respect the max. load  
 Maximale Nutzlast beachten  
 Rispettare il carico max.

**Notes**  
**Material:** CK45 - 800÷1000 N/mm<sup>2</sup>

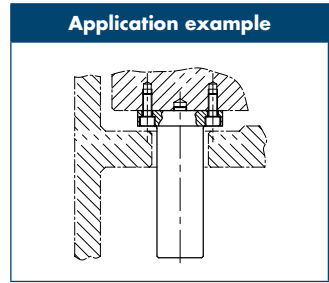

ORDER EXAMPLE	Art.	TYPE	L=220
	C12.11.	11	220

OMCR CODE	TYPE	Max Load (kN)
C12.11.	11	80
C12.11.	12	80

## AIR PIN VDI 3002 - DRUCKBOLZEN VDI 3002 - CANDELA VDI 3002

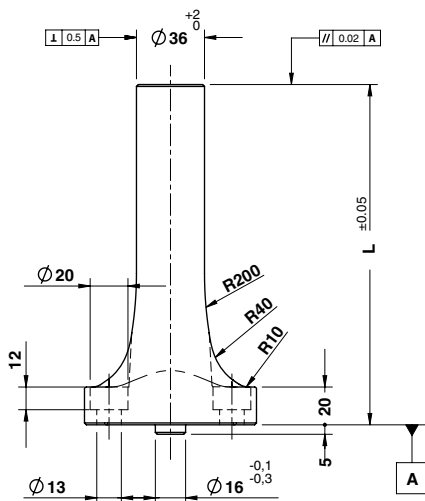

**TYPE 10**

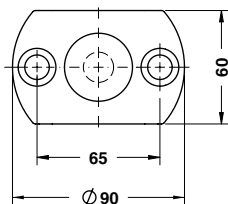

STOCK



WEB



Respect the max. load  
Maximale Nutzlast beachten  
Rispettare il carico max.

### Notes

**Material:** CK45  
800÷1000 N/mm<sup>2</sup>



Art.	TYPE	L=220
C12.12.	10	220

OMCR CODE	TYPE	L	Max Load (kN)	OMCR CODE	TYPE	L	Max Load (kN)	OMCR CODE	TYPE	L	Max Load (kN)
C12.12.10150	10	150	50	C12.12.10215	10	215	50	C12.12.10280	10	280	50
C12.12.10155	10	155	50	C12.12.10220	10	220	50	C12.12.10285	10	285	50
C12.12.10160	10	160	50	C12.12.10225	10	225	50	C12.12.10290	10	290	50
C12.12.10165	10	165	50	C12.12.10230	10	230	50	C12.12.10295	10	295	50
C12.12.10170	10	170	50	C12.12.10235	10	235	50	C12.12.10300	10	300	50
C12.12.10175	10	175	50	C12.12.10240	10	240	50	C12.12.10310	10	310	50
C12.12.10180	10	180	50	C12.12.10245	10	245	50	C12.12.10320	10	320	50
C12.12.10185	10	185	50	C12.12.10250	10	250	50	C12.12.10330	10	330	50
C12.12.10190	10	190	50	C12.12.10255	10	255	50	C12.12.10340	10	340	50
C12.12.10195	10	195	50	C12.12.10260	10	260	50	C12.12.10350	10	350	50
C12.12.10200	10	200	50	C12.12.10265	10	265	50	C12.12.10360	10	360	50
C12.12.10205	10	205	50	C12.12.10270	10	270	50				
C12.12.10210	10	210	50	C12.12.10275	10	275	50				



AIR PIN VDI 3002 - DRUCKBOLZEN VDI 3002 - CANDELA VDI 3002

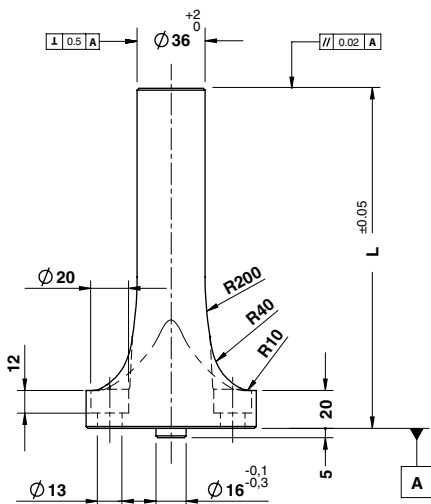

TYPE 11

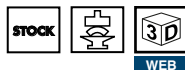
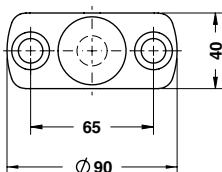

⚠  
 Respect the max. load  
 Maximale Nutzlast beachten  
 Rispettare il carico max.

**Notes**  
**Material:** CK45  
 800÷1000 N/mm<sup>2</sup>

ORDER EXAMPLE	Art.	TYPE	L=220
	C12.12.	11	220

OMCR CODE	TYPE	L	Max Load (kN)	OMCR CODE	TYPE	L	Max Load (kN)	OMCR CODE	TYPE	L	Max Load (kN)
C12.12.11150	11	150	50	C12.12.11215	11	215	50	C12.12.11280	11	280	50
C12.12.11155	11	155	50	C12.12.11220	11	220	50	C12.12.11285	11	285	50
C12.12.11160	11	160	50	C12.12.11225	11	225	50	C12.12.11290	11	290	50
C12.12.11165	11	165	50	C12.12.11230	11	230	50	C12.12.11295	11	295	50
C12.12.11170	11	170	50	C12.12.11235	11	235	50	C12.12.11300	11	300	50
C12.12.11175	11	175	50	C12.12.11240	11	240	50	C12.12.11310	11	310	50
C12.12.11180	11	180	50	C12.12.11245	11	245	50	C12.12.11320	11	320	50
C12.12.11185	11	185	50	C12.12.11250	11	250	50	C12.12.11330	11	330	50
C12.12.11190	11	190	50	C12.12.11255	11	255	50	C12.12.11340	11	340	50
C12.12.11195	11	195	50	C12.12.11260	11	260	50	C12.12.11350	11	350	50
C12.12.11200	11	200	50	C12.12.11265	11	265	50	C12.12.11360	11	360	50
C12.12.11205	11	205	50	C12.12.11270	11	270	50				
C12.12.11210	11	210	50	C12.12.11275	11	275	50				

AIR PIN VDI 3002 - DRUCKBOLZEN VDI 3002 - CANDELA VDI 3002

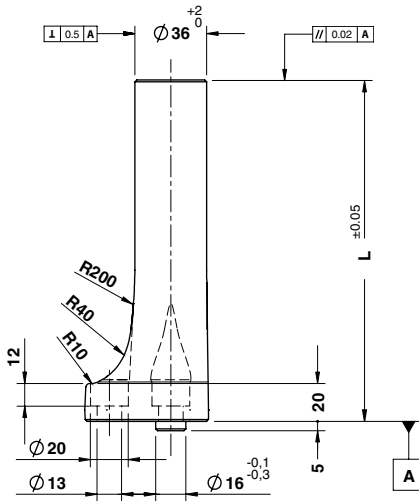

TYPE 12

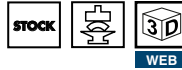
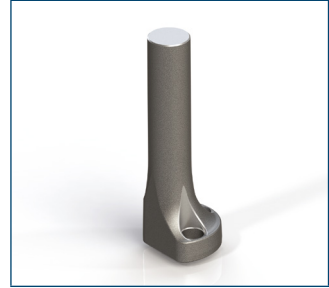
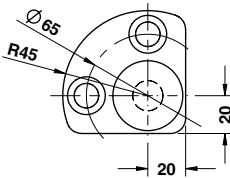

⚠  
 Respect the max. load  
 Maximale Nutzlast beachten  
 Rispettare il carico max.

**Notes**  
**Material:** CK45  
 800 ÷ 1000 N/mm<sup>2</sup>

ORDER EXAMPLE	Art.	TYPE	L=220
	C12.12.	12	220

OMCR CODE	TYPE	L	Max Load (kN)	OMCR CODE	TYPE	L	Max Load (kN)	OMCR CODE	TYPE	L	Max Load (kN)
C12.12.12150	12	150	50	C12.12.12215	12	215	50	C12.12.12280	12	280	50
C12.12.12155	12	155	50	C12.12.12220	12	220	50	C12.12.12285	12	285	50
C12.12.12160	12	160	50	C12.12.12225	12	225	50	C12.12.12290	12	290	50
C12.12.12165	12	165	50	C12.12.12230	12	230	50	C12.12.12295	12	295	50
C12.12.12170	12	170	50	C12.12.12235	12	235	50	C12.12.12300	12	300	50
C12.12.12175	12	175	50	C12.12.12240	12	240	50	C12.12.12310	12	310	50
C12.12.12180	12	180	50	C12.12.12245	12	245	50	C12.12.12320	12	320	50
C12.12.12185	12	185	50	C12.12.12250	12	250	50	C12.12.12330	12	330	50
C12.12.12190	12	190	50	C12.12.12255	12	255	50	C12.12.12340	12	340	50
C12.12.12195	12	195	50	C12.12.12260	12	260	50	C12.12.12350	12	350	50
C12.12.12200	12	200	50	C12.12.12265	12	265	50	C12.12.12360	12	360	50
C12.12.12205	12	205	50	C12.12.12270	12	270	50				
C12.12.12210	12	210	50	C12.12.12275	12	275	50				

AIR PIN VDI 3002 - DRUCKBOLZEN VDI 3002 - CANDELA VDI 3002

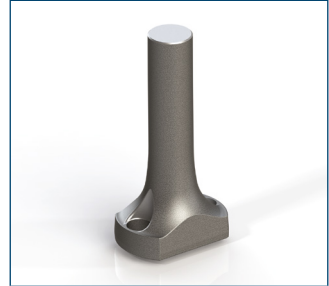
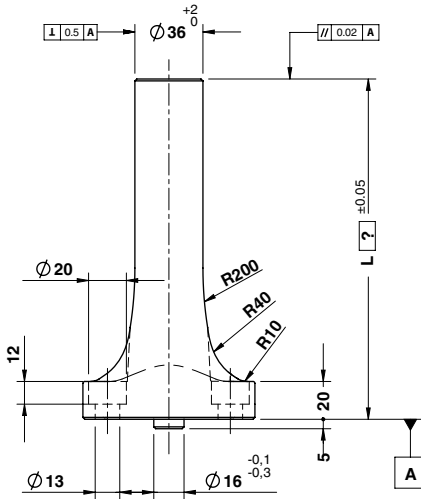

Standard OMCR



**L<sub>max</sub> = 360 mm**  
 Respect the max. load  
 Maximale Nutzlast beachten  
 Rispettare il carico max.

**Notes**  
**Material:** C45  
 800 ÷ 1000 N/mm<sup>2</sup>

**TYPE 10**

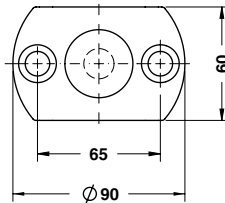

**TYPE 11**

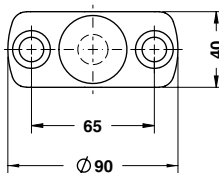

**TYPE 12**

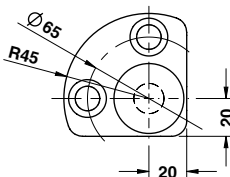

Art.	TYPE	L=220
C12.12.	10	220

OMCR CODE	TYPE	Max Load (kN)
C12.12.	10	50
C12.12.	11	50
C12.12.	12	50

## SPACER PLATE TOOTHED - DISTANZPLATTE GEZAHNT - TASSELLO DI COMPENSAZIONE

**Notes**

**1 2 3**  
**Material:** 90MnCrV8  
**HRC:** 58±60

**4** **Material:** X155CrVMo12

**5** DIN 912

**Application example**

0.02 mm each tooth  
 Pro Zahn 0.02 mm  
 0.02 mm a dente

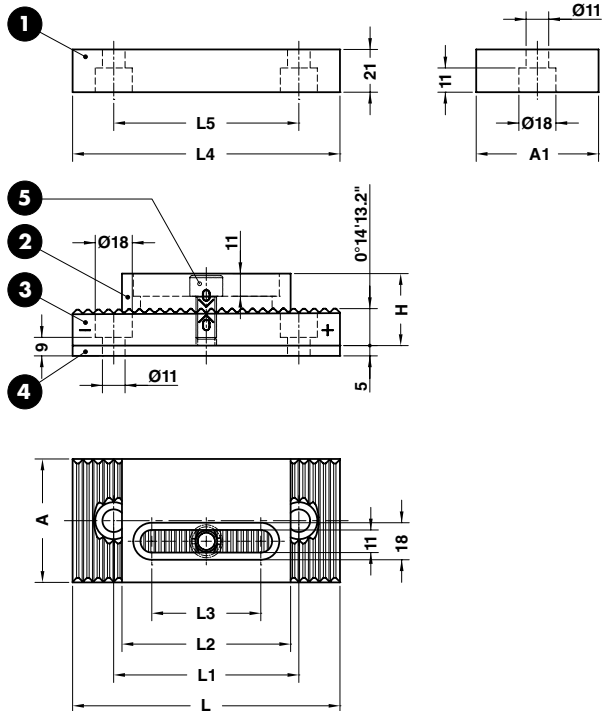
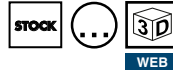

	Art.	A=60	H=35	L=130
	C12.16.	060	35	130

OMCR CODE	A	A1	H	H min.	H max.	L	L1	L2	L3	L4	L5
C12.16.06035130	60	60	35	34,88	35,12	130	90	90	61	130	90
C12.16.08035160	80	80	35	34,86	35,14	160	120	110	71	160	120

## COMPENSATION BLOCK - ABSTANDSBLOCK - TASSELLO DI COMPENSAZIONE

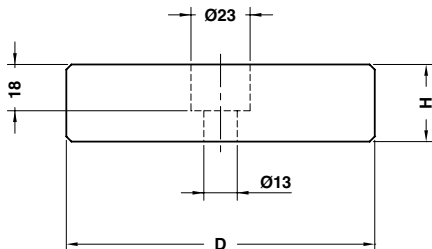

STOCK

3D  
WEB



### Notes

**Material:** 42CrMo4 · **HRC:** 46÷48

ORDER EXAMPLE	Art.	D=80	H=25
	C12.20.	080	25

OMCR CODE	D	H
C12.20.08025	80	25
C12.20.08030	80	30
C12.20.10025	100	25
C12.20.10030	100	30
C12.20.12025	120	25
C12.20.12030	120	30

Standard OMCR

## SHIM - AUSGLEICHSCHEIB - SPESSORE

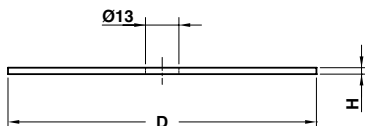

STOCK

3D  
WEB



### Notes

**Material:** CK45

ORDER EXAMPLE	Art.	D=80	H=0,5
	C12.21.	080	05

OMCR CODE	D	H	Material
C12.21.08001	80	0,1	BRASS
C12.21.08005	80	0,5	STEEL
C12.21.10001	100	0,1	BRASS
C12.21.10005	100	0,5	STEEL
C12.21.12001	120	0,1	BRASS
C12.21.12005	120	0,5	STEEL

PRESSURE PLATE - DRUCKPLATTE - PIASTRA DI REAZIONE

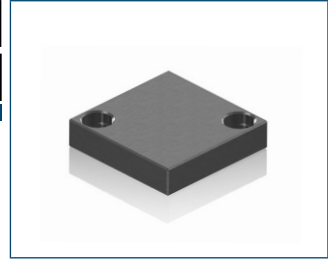

Notes

Material: 16MnCr5 - HRC: 58÷60

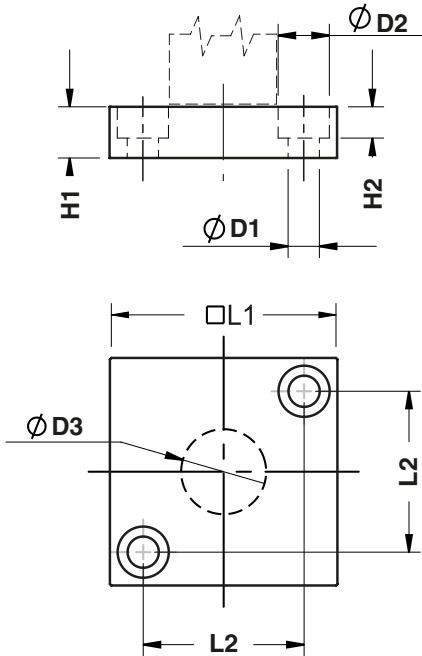

Art.	L1=60	H1=15
C12.22.	060	15

OMCR CODE	L1	L2	D1	D2	D3	H1	H2
C12.22.04012	40	24	7	11	≤ 20	12	7
C12.22.06015	60	40	9	15	≤ 36	15	9
C12.22.07015	70	50	9	15	≤ 50	15	9
C12.22.08018	80	56,5	11	18	≤ 65	18	11
C12.22.10020	100	74	11	18	≤ 80	20	11
C12.22.14020	140	110	11	18	≤ 95	20	11

PRESSURE PLATE - DRUCKPLATTE - PIASTRA DI REAZIONE

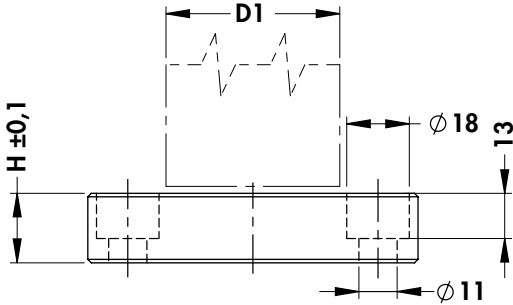

Notes

Material: 16MnCr5 - HRC: 58+60

FORM A

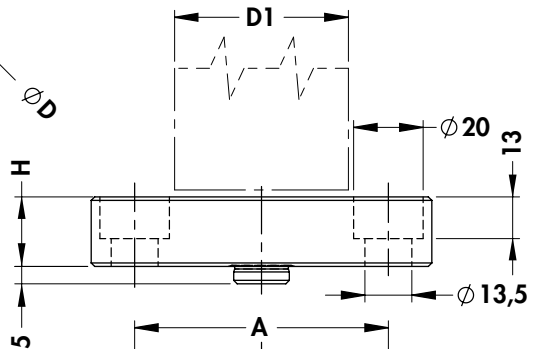
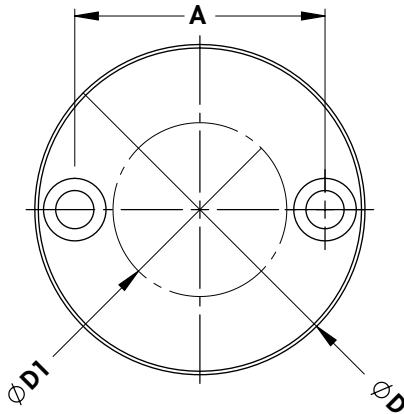

FORM B

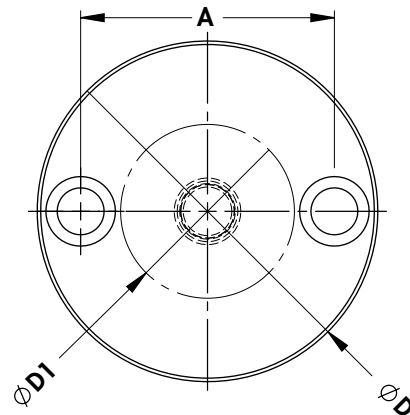

ORDER EXAMPLE	Art.	D=95	H=20
	C12.23.	095	20

OMCR CODE	A	D	D1	H	FORM
C12.23.06520	42	65	≤ 25	20	A
C12.23.09520	72	95	≤ 50	20	A
C12.23.09820	73	98	≤ 50	20	B
C12.23.11320	88	113	≤ 60	20	B
C12.23.12820	103	128	≤ 75	20	B
C12.23.14320	118	143	≤ 95	20	B

## PRESSURE PLATE - DRUCKPLATTE - PIASTRA DI REAZIONE

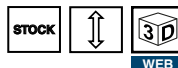
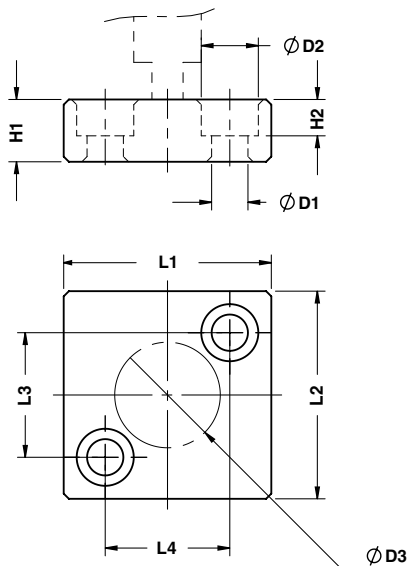

### Notes

**Material:** 90MnCrV8  
**HRC:** 50÷52



Art.	L1=100	L2=80	H1=20
C12.24.	100	080	20

OMCR CODE	L1	L2	L3	L4	H1	H2	D1	D2	D3
C12.24.04004012	40	40	24	24	12	7	7	11	≤ 20
C12.24.04004015	40	40	21	21	15	10	9	15	≤ 15
C12.24.05002512	50	25	8	32	12	7	7	11	≤ 15
C12.24.05003012	50	30	14	35	12	7	7	11	≤ 20
C12.24.05605620	56	56	32	32	20	13	11	18	≤ 25
C12.24.06006012	60	60	38	38	12	9	9	15	≤ 36
C12.24.06006015	60	60	40	40	15	9	9	15	≤ 36
C12.24.07003515	70	35	14	48	15	9	9	15	≤ 25
C12.24.07005015	70	50	30	56	15	9	9	15	≤ 36
C12.24.07007015	70	70	50	50	15	9	9	15	≤ 50
C12.24.07107120	71	71	48	48	20	13	11	18	≤ 50
C12.24.08506015	80	60	40	56	15	9	9	15	≤ 50
C12.24.09009012	90	90	70	70	12	9	9	15	≤ 75
C12.24.09009020	90	90	67	67	20	13	11	18	≤ 65
C12.24.10008020	100	80	56	72	20	11	11	18	≤ 65
C12.24.10010012	100	100	81	81	12	9	9	15	≤ 90
C12.24.10010020	100	100	74	74	20	11	11	18	≤ 80
C12.24.11010020	110	100	75	85	20	11	11	18	≤ 95
C12.24.11011020	110	110	84	84	20	11	11	18	≤ 95
C12.24.14014020	140	140	110	110	20	13	11	18	≤ 95



## BALANCE BLOCK - DISTANZSTÜCK - DISTANZIALE

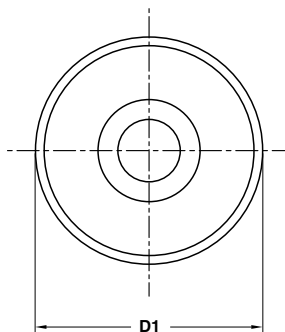
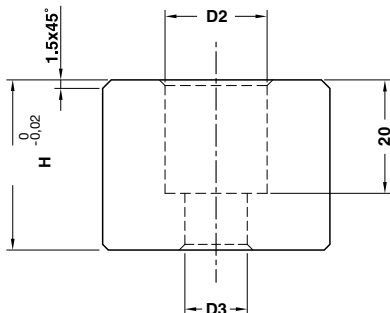

**Notes**  
**Material: CK45**

Standard OMCR

	Art.	D1=40	H=30
	C12.25.	040	30

OMCR CODE	D1	D2	D3	H
C12.25.04030	40	18	11	30
C12.25.06050	60	20	13,5	50
C12.25.10050	100	20	13,5	50

## BALANCE BLOCK - DISTANZSTÜCK - DISTANZIALE

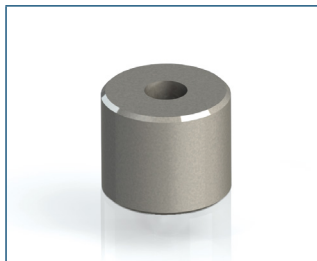
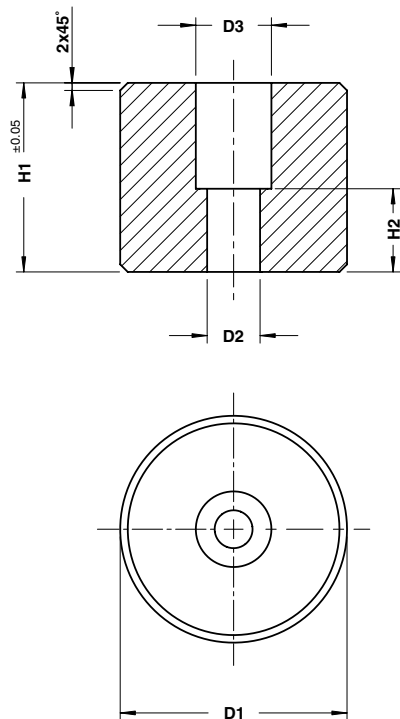

Respect the max. load  
 Maximale Nutzlast beachten  
 Rispettare il carico max.

**Notes**

**Material:** CK45  
 Screws not included  
 Unpainted

	Art.	D1=60	H1=40,50
	C12.26.	060	04050

## BALANCE BLOCK - DISTANZSTÜCK - DISTANZIALE

D1	25		30		40		50		60		80		100		120		150			
D2	9		9		9		9		14		14		18		22		22			
D3	15		15		15		15		20		20		26		33		33			
Max load (t)	3.5		8		20		35		55		100		170		250		400			
H2	10	28	10	28	10	28	10	28	12	22	42	12	22	42	20	36	15	30	15	30
Screw DIN EN ISO 4762	M8x25	M8x40	M8x25	M8x40	M8x25	M8x40	M8x25	M8x40	M12x30	M12x40	M12x60	M12x30	M12x40	M12x60	M16x40	M16x60	M20x50	M20x60	M20x50	M20x60
H1																				
20	•		•		•		•													
20,3	•		•		•		•													
20,5	•		•		•		•													
23	•		•		•		•													
25	•		•		•		•		•											
28	•		•		•		•		•											
30	•		•		•		•		•			•								
30,3	•		•		•		•		•			•								
30,5	•		•		•		•		•			•								
33	•		•		•		•		•			•								
35	•		•		•		•		•			•								
38	•		•		•		•		•			•								
40	•		•		•		•			•			•		•					
40,3		•		•		•		•		•			•		•					
40,5		•		•		•		•		•			•		•					
41			•		•		•		•			•		•						
43			•		•		•		•			•		•						
45			•		•		•		•			•		•						
48			•		•		•		•			•		•						
50			•		•		•		•			•		•						•
50,3			•		•		•		•			•		•						•
50,5			•		•		•		•			•		•						•
51			•		•		•		•			•		•						•
55			•		•		•		•			•		•						•
60			•		•		•		•			•		•						•
60,3			•		•		•		•		•		•		•					•
60,5			•		•		•		•		•		•		•					•
61			•		•		•		•		•		•		•					•

Standard OMCR

## BALANCE BLOCK - DISTANZSTÜCK - DISTANZIALE

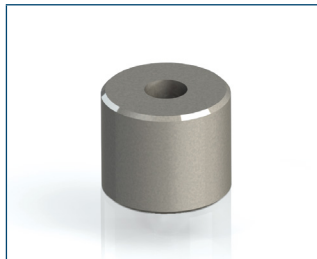
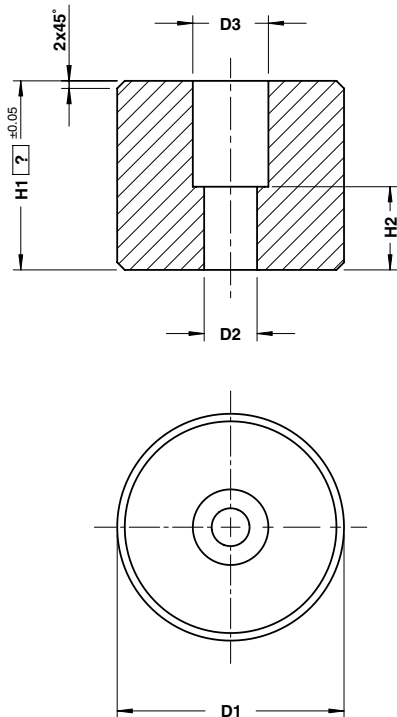

**10** **3D**  
WEB

**⚠**  
Respect the max. load  
Maximale Nutzlast beachten  
Rispettare il carico max.

**Notes**

**Material:** CK45  
Screws not included  
Unpainted

<b>ORDER EXAMPLE</b> 	<b>Art.</b>	<b>D1=80</b>	<b>H1=45</b>
	<b>C12.26.</b>	<b>080</b>	<b>04500</b>

OMCR CODE	D1	D2	D3	H1	H2	Screw DIN EN ISO 4762	Max load (t)
<b>C12.26.</b>	25	9	15	≥ 20 - 40	10	M8x25	3,5
<b>C12.26.</b>	25	9	15	> 40 - 60	28	M8x40	3,5
<b>C12.26.</b>	30	9	15	≥ 20 - 40	10	M8x25	8
<b>C12.26.</b>	30	9	15	> 40 - 60	28	M8x40	8
<b>C12.26.</b>	40	9	15	≥ 20 - 40	10	M8x25	20
<b>C12.26.</b>	40	9	15	> 40 - 60	28	M8x40	20
<b>C12.26.</b>	50	9	15	≥ 20 - 40	10	M8x25	35
<b>C12.26.</b>	50	9	15	> 40 - 60	28	M8x40	35

## BALANCE BLOCK - DISTANZSTÜCK - DISTANZIALE

OMCR CODE	D1	D2	D3	H1	H2	Screw DIN EN ISO 4762	Max load (t)
C12.26.	60	14	20	≥ 25 < 40	12	M12x30	55
C12.26.	60	14	20	≥ 40 - 60	22	M12x40	55
C12.26.	60	14	20	> 60 - 80	42	M12x60	55
C12.26.	60	14	20	> 80 - 100	62	M12x80	55
C12.26.	60	14	20	> 100 - 120	82	M12x100	55
C12.26.	60	14	20	> 120 - 140	102	M12x120	55
C12.26.	60	14	20	> 140 - 160	122	M12x140	55
C12.26.	80	14	20	≥ 25 < 40	12	M12x30	100
C12.26.	80	14	20	≥ 40 - 60	20	M12x40	100
C12.26.	80	14	20	> 60 - 80	36	M12x60	100
C12.26.	80	14	20	> 80 - 100	56	M12x80	100
C12.26.	80	14	20	> 100 - 120	76	M12x100	100
C12.26.	80	14	20	> 120 - 140	96	M12x120	100
C12.26.	80	14	20	> 140 - 160	116	M12x140	100
C12.26.	100	18	26	≥ 40 - 60	20	M16x40	170
C12.26.	100	18	26	> 60 - 80	36	M16x60	170
C12.26.	100	18	26	> 80 - 100	56	M16x80	170
C12.26.	100	18	26	> 100 - 120	76	M16x100	170
C12.26.	100	18	26	> 120 - 140	96	M16x120	170
C12.26.	100	18	26	> 140 - 160	116	M16x140	170
C12.26.	120	22	33	≥ 40 - 60	15	M20x40	250
C12.26.	120	22	33	> 60 - 80	30	M20x60	250
C12.26.	120	22	33	> 80 - 100	50	M20x80	250
C12.26.	120	22	33	> 100 - 120	70	M20x100	250
C12.26.	120	22	33	> 120 - 140	90	M20x120	250
C12.26.	120	22	33	> 140 - 160	110	M20x140	250
C12.26.	150	22	33	≥ 40 - 60	15	M20x40	400
C12.26.	150	22	33	> 60 - 80	30	M20x60	400
C12.26.	150	22	33	> 80 - 100	50	M20x80	400
C12.26.	150	22	33	> 100 - 120	70	M20x100	400
C12.26.	150	22	33	> 120 - 140	90	M20x120	400
C12.26.	150	22	33	> 140 - 160	110	M20x140	400

BALANCE BLOCK - DISTANZSTÜCK - DISTANZIALE

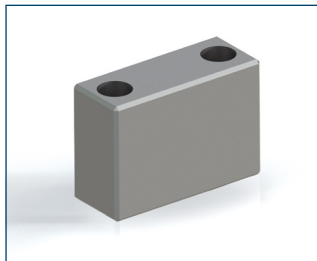
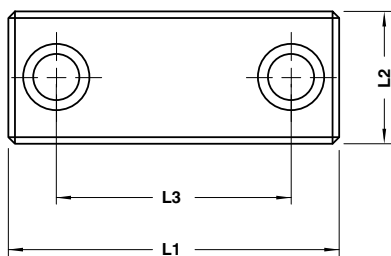
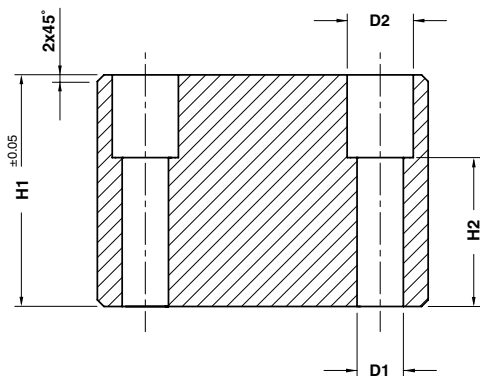

Respect the max. load  
 Maximale Nutzlast beachten  
 Rispettare il carico max.

**Notes**

**Material:** CK45  
 Screws not included  
 Unpainted

	Art.	L1=60	L2=40	H1=60,5
	C12.27.	060	040	06050

**BALANCE BLOCK - DISTANZSTÜCK - DISTANZIALE**

L1 x L2	60 x 40			80 x 40			100 x 40			100 x 50			120 x 60			150 x 80		160 x 100	
D1	9			11			14			14			14			18		18	
D2	15			18			20			20			20			26		26	
Max load (t)	50			65			85			110			160			270		380	
L3	40			56			71			76			93			120		130	
H2	10	28	48	8	25	45	6	22	42	6	22	42	6	22	42	18	38	18	38
Screw DIN EN ISO 4762	M8x25	M8x40	M8x60	M10x25	M10x40	M10x60	M12x25	M12x40	M12x60	M12x25	M12x40	M12x60	M12x25	M12x40	M12x60	M16x40	M16x60	M16x40	M16x60

H1																			
20	•			•															
20,3	•			•															
20,5	•			•															
23	•			•															
25	•			•			•												
28	•			•			•												
30	•			•			•			•									
30,3	•			•			•			•									
30,5	•			•			•			•									
33	•			•			•			•									
35	•			•			•			•									
38	•			•			•			•									
40	•			•			•			•			•			•			•
40,3		•			•			•			•			•		•			•
40,5		•			•			•			•			•		•			•
41		•			•			•			•			•		•			•
43		•			•			•			•			•		•			•
45		•			•			•			•			•		•			•
48		•			•			•			•			•		•			•
50		•			•			•			•			•		•			•
50,3		•			•			•			•			•		•			•
50,5		•			•			•			•			•		•			•
51		•			•			•			•			•		•			•
55		•			•			•			•			•		•			•
60		•			•			•			•			•		•			•
60,5			•			•			•			•			•		•		•
61									•			•			•		•		•

Standard OMCR

## BALANCE BLOCK - DISTANZSTÜCK - DISTANZIALE

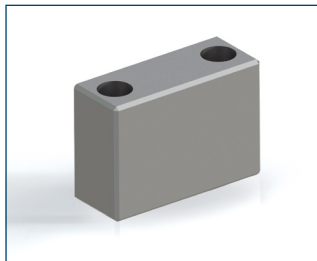
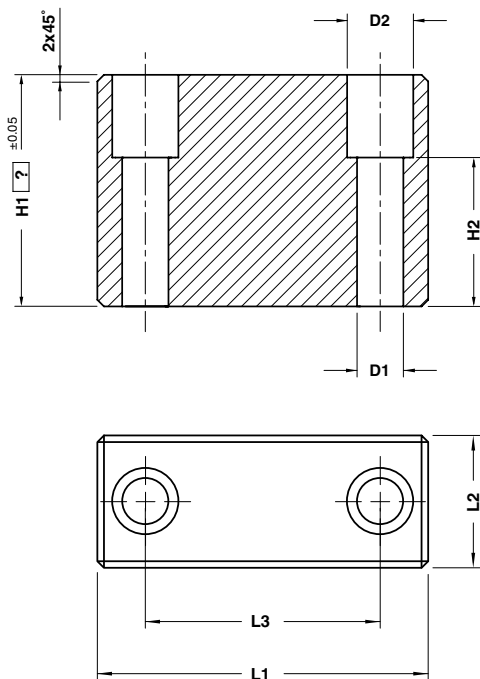

Respect the max. load  
 Maximale Nutzlast beachten  
 Rispettare il carico max.

**Notes**

**Material:** CK45  
 Screws not included  
 Unpainted

Art.	L1=150	L2=80	H1=85
C12.27.	150	080	08500

OMCR CODE	D1	D2	H1	H2	L1	L2	L3	Screw DIN EN ISO 4762	Max load (t)
C12.27.	9	15	≥ 20 - 40	10	60	40	40	M8x25	50
C12.27.	9	15	> 40 - 60	28	60	40	40	M8x40	50
C12.27.	9	15	> 60 - 80	48	60	40	40	M8x60	50
C12.27.	9	15	> 80 - 100	68	60	40	40	M8x80	50
C12.27.	9	15	> 100 - 120	68	60	40	40	M8x80	50
C12.27.	9	15	> 120 - 140	68	60	40	40	M8x80	50
C12.27.	9	15	> 140 - 160	68	60	40	40	M8x80	50
C12.27.	11	18	≥ 20 - 40	8	80	40	56	M10x25	65
C12.27.	11	18	> 40 - 60	25	80	40	56	M10x40	65
C12.27.	11	18	> 60 - 80	45	80	40	56	M10x60	65
C12.27.	11	18	> 80 - 100	65	80	40	56	M10x80	65
C12.27.	11	18	> 100 - 120	85	80	40	56	M10x100	65
C12.27.	11	18	> 120 - 140	105	80	40	56	M10x120	65
C12.27.	11	18	> 140 - 160	105	80	40	56	M10x120	65
C12.27.	14	20	≥ 20 - 40	6	100	40	71	M12x25	85
C12.27.	14	20	> 40 - 60	22	100	40	71	M12x40	85
C12.27.	14	20	> 60 - 80	42	100	40	71	M12x60	85
C12.27.	14	20	> 80 - 100	62	100	40	71	M12x80	85
C12.27.	14	20	> 100 - 120	82	100	40	71	M12x100	85
C12.27.	14	20	> 120 - 140	102	100	40	71	M12x120	85



## BALANCE BLOCK - DISTANZSTÜCK - DISTANZIALE

OMCR CODE	D1	D2	H1	H2	L1	L2	L3	Screw DIN EN ISO 4762	Max load (t)
C12.27.	14	20	> 140 - 160	122	100	40	71	M12x140	85
C12.27.	14	20	≥ 20 - 40	6	100	50	76	M12x25	110
C12.27.	14	20	> 40 - 60	22	100	50	76	M12x40	110
C12.27.	14	20	> 60 - 80	42	100	50	76	M12x60	110
C12.27.	14	20	> 80 - 100	62	100	50	76	M12x80	110
C12.27.	14	20	> 100 - 120	82	100	50	76	M12x100	110
C12.27.	14	20	> 120 - 140	102	100	50	76	M12x120	110
C12.27.	14	20	> 140 - 160	122	100	50	76	M12x140	110
C12.27.	14	20	≥ 20 - 40	6	120	60	93	M12x25	160
C12.27.	14	20	> 40 - 60	22	120	60	93	M12x40	160
C12.27.	14	20	> 60 - 80	42	120	60	93	M12x60	160
C12.27.	14	20	> 80 - 100	62	120	60	93	M12x80	160
C12.27.	14	20	> 100 - 120	82	120	60	93	M12x100	160
C12.27.	14	20	> 120 - 140	102	120	60	93	M12x120	160
C12.27.	14	20	> 140 - 160	122	120	60	93	M12x140	160
C12.27.	18	26	> 40 - 60	18	150	80	120	M16x40	270
C12.27.	18	26	> 60 - 80	38	150	80	120	M16x60	270
C12.27.	18	26	> 80 - 100	58	150	80	120	M16x80	270
C12.27.	18	26	> 100 - 120	78	150	80	120	M16x100	270
C12.27.	18	26	> 120 - 140	98	150	80	120	M16x120	270
C12.27.	18	26	> 140 - 160	118	150	80	120	M16x140	270
C12.27.	18	26	> 40 - 60	18	160	100	130	M16x40	380
C12.27.	18	26	> 60 - 80	38	160	100	130	M16x60	380
C12.27.	18	26	> 80 - 100	58	160	100	130	M16x80	380
C12.27.	18	26	> 100 - 120	78	160	100	130	M16x100	380
C12.27.	18	26	> 120 - 140	98	160	100	130	M16x120	380
C12.27.	18	26	> 140 - 160	118	160	100	130	M16x140	380

BALANCE BLOCK - DISTANZSTÜCK - DISTANZIALE

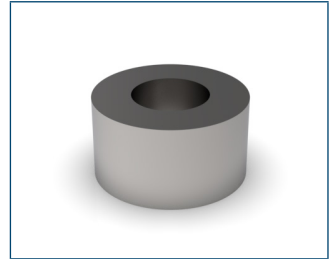
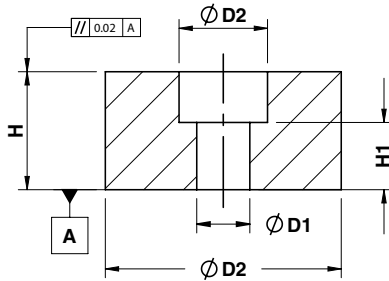

**⚠**  
 Respect the max. load  
 Maximale Nutzlast beachten  
 Rispettare il carico max.

**Notes**  
**Material:** CK45  
 Screws not included  
 Unpainted

ORDER EXAMPLE	Art.	D=70	H=30	Screw
	C12.28.	070	030	M12

OMCR CODE	D	D1	D2	H	H1	Screw
C12.28.040020M12	40	13	20	20	6	M12
C12.28.070030M08	70	9	15	30	16	M08
C12.28.070030M12	70	13	20	30	15	M12



**SPACING BAR - ABSTELLBOLZEN - DISTANZIALE**

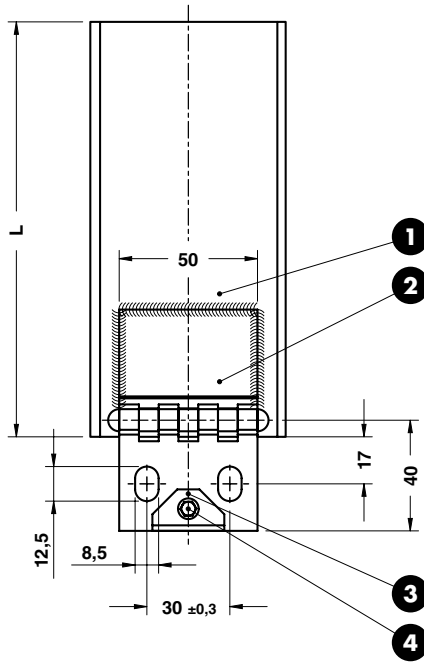

**TYPE 02**

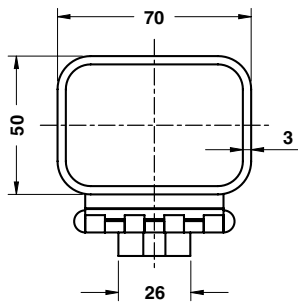

## SPACING BAR - ABSTELLBOLZEN - DISTANZIALE



Respect the max. load  
 Maximale Nutzlast beachten  
 Rispettare il carico max.

### Notes

- 1 Material:** St37
- 2** AHA Hinge
- 3 Material:** Elastomer 68SH
- 4** Screw M4x8 - DIN912

### Application example

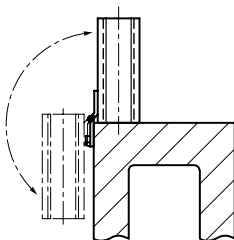

Standard OMCR

	Art.	TYPE	L=70
	C12.30.	02	070

OMCR CODE	TYPE	L	Max load (kN)	OMCR CODE	TYPE	L	Max load (kN)	OMCR CODE	TYPE	L	Max load (kN)
C12.30.02065	02	65	100	C12.30.02150	02	150	100	C12.30.02230	02	230	100
C12.30.02070	02	70	100	C12.30.02155	02	155	100	C12.30.02235	02	235	100
C12.30.02075	02	75	100	C12.30.02160	02	160	100	C12.30.02240	02	240	100
C12.30.02080	02	80	100	C12.30.02165	02	165	100	C12.30.02245	02	245	100
C12.30.02085	02	85	100	C12.30.02170	02	170	100	C12.30.02250	02	250	100
C12.30.02090	02	90	100	C12.30.02175	02	175	100	C12.30.02260	02	260	100
C12.30.02095	02	95	100	C12.30.02180	02	180	100	C12.30.02270	02	270	100
C12.30.02100	02	100	100	C12.30.02185	02	185	100	C12.30.02280	02	280	100
C12.30.02105	02	105	100	C12.30.02190	02	190	100	C12.30.02290	02	290	100
C12.30.02110	02	110	100	C12.30.02195	02	195	100	C12.30.02300	02	300	100
C12.30.02115	02	115	100	C12.30.02200	02	200	100	C12.30.02310	02	310	100
C12.30.02120	02	120	100	C12.30.02205	02	205	100	C12.30.02320	02	320	100
C12.30.02125	02	125	100	C12.30.02210	02	210	100	C12.30.02330	02	330	100
C12.30.02130	02	130	100	C12.30.02215	02	215	100	C12.30.02340	02	340	100
C12.30.02135	02	135	100	C12.30.02220	02	220	100	C12.30.02350	02	350	100
C12.30.02140	02	140	100	C12.30.02225	02	225	100				

## SPACING BAR - ABSTELLBOLZEN - DISTANZIALE

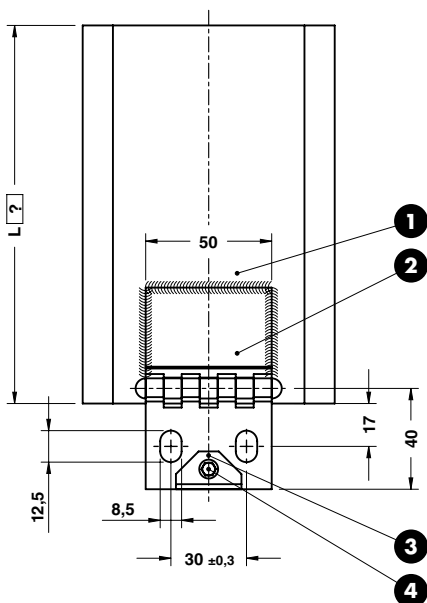

**TYPE 01**

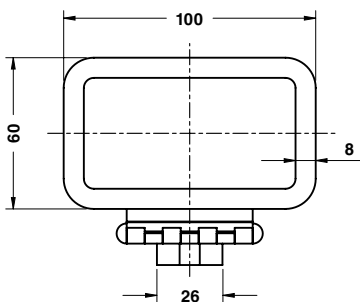

**TYPE 02**

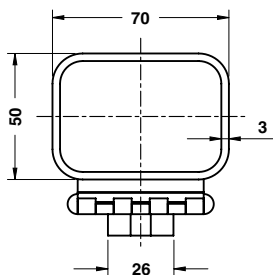

L max. = 400

Respect the max. load  
Maximale Nutzlast beachten  
Rispettare il carico max.

### Notes

- 1** Material: Si37
- 2** AHA Hinge
- 3** Material: Elastomer 68SH
- 4** Screw M4x8 - DIN912

### Application example

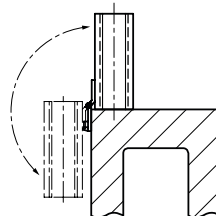

ORDER EXAMPLE	Art.	TYPE	L=200
	C12.30.	01	200
OMCR CODE	TYPE	Max load (kN)	
C12.30.	01	300	
C12.30.	02	100	

## SPACING BAR - ABSTELLBOLZEN - DISTANZIALE

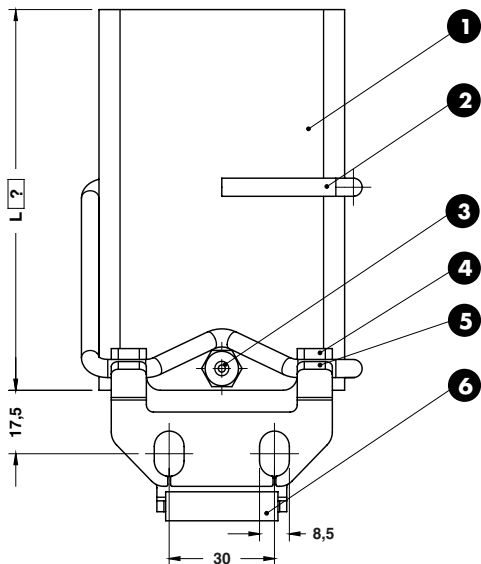

**TYPE 03**

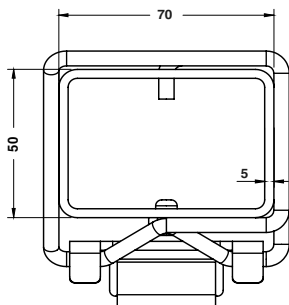

**TYPE 04**

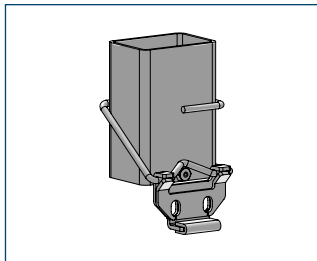
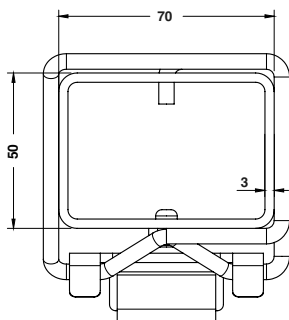

**Notes**

$80 \leq L \leq 400$

Respect the max. load  
 Maximale Nutzlast beachten  
 Rispettare il carico max.

- Notes**
- 1 **Material:** Si37
  - 2 Steel spring
  - 3 Rivet
  - 4 Plate
  - 5 Plate
  - 6 PVC

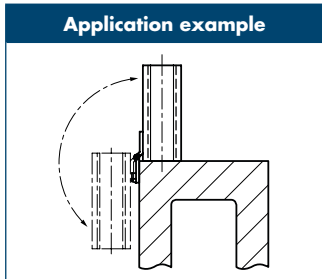

OMCR CODE	TYPE	Max load (kN)
C12.30.	03	235
C12.30.	04	125

Standard OMCR

## PAD RETAINER PIN VDI 3365 - STECKBOLZEN VDI 3365 - PERNO DI ARRESTO VDI 3365



Respect the dynamic load  
Dynamische Last berücksichtigen  
Rispettare il carico dinamico

### Notes

- 1** Material: 42CrMo4  
800±1000 N/mm<sup>2</sup>
- 2** Material: CK45
- 3** Screw M12x20 - DIN 912

### Application example

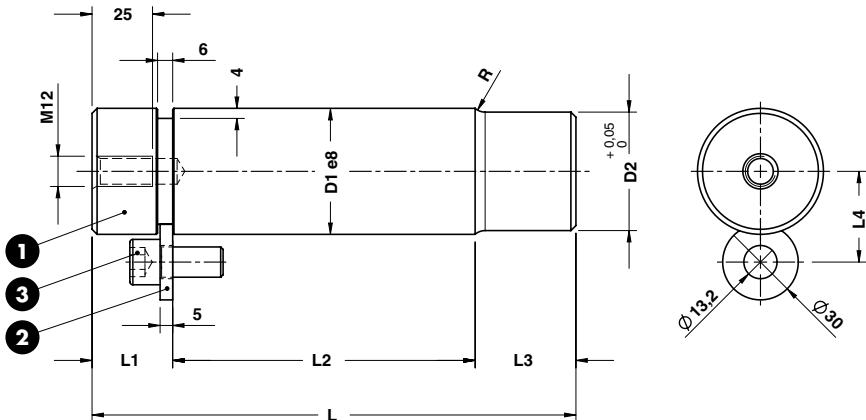
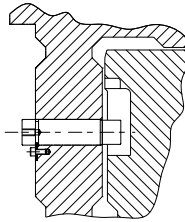

ORDER EXAMPLE	Art.	D1=32	L=105
	C13.10.	32	105

OMCR CODE	D1	D2	L	L1	L2	L3	L4	R	Dynamic load (kN)
C13.10.32105	32	29	105	22	58	25	27	4	3
C13.10.32122	32	29	122	22	75	25	27	4	3
C13.10.40139	40	37	139	32	75	32	31	5	5
C13.10.40159	40	37	159	32	95	32	31	5	5
C13.10.50167	50	47	167	32	95	40	36	6	7,5
C13.10.50192	50	47	192	32	120	40	36	6	7,5
C13.10.63202	63	60	202	32	120	50	42,5	6	12,5
C13.10.63237	63	60	237	32	155	50	42,5	6	12,5



## PAD RETAINER PIN VDI 3365 - STECKBOLZEN VDI 3365 - PERNO DI ARRESTO VDI 3365



Respect the dynamic load  
Dynamische Last berücksichtigen  
Rispettare il carico dinamico

### Notes

- 1** Material: 42CrMo4  
800±1000 N/mm<sup>2</sup>
- 2** Material: CK45
- 3** Screw M12x20 - DIN 912

### Application example

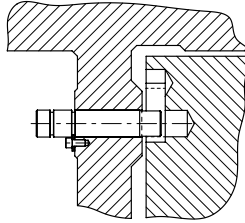

Standard OMCR

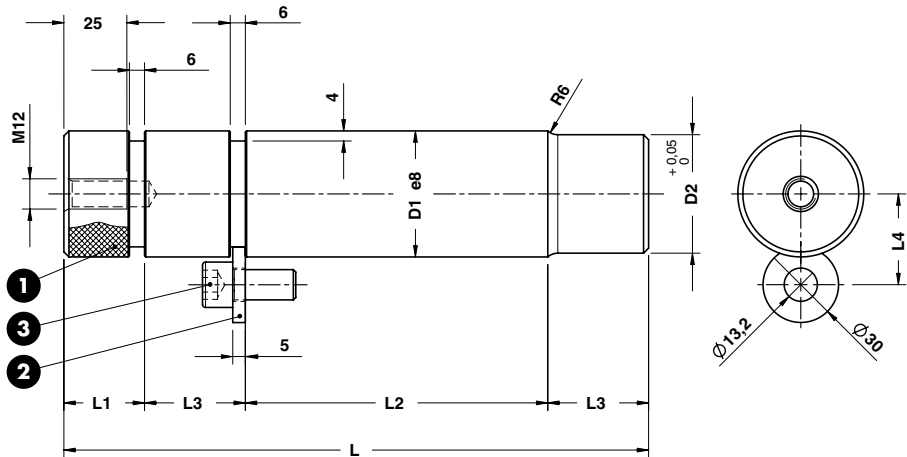

ORDER EXAMPLE	Art.	D1=32	L=130
	C13.11.	32	130

OMCR CODE	D1	D2	L	L1	L2	L3	L4	R	Dynamic load (kN)
C13.11.32130	32	29	130	22	58	25	27	4	3
C13.11.32147	32	29	147	22	75	25	27	4	3
C13.11.40171	40	37	171	32	75	32	31	5	5
C13.11.40191	40	37	191	32	95	32	31	5	5
C13.11.50207	50	47	207	32	95	40	36	6	7,5
C13.11.50232	50	47	232	32	120	40	36	6	7,5
C13.11.63252	63	60	252	32	120	50	42,5	6	12,5
C13.11.63287	63	60	287	32	155	50	42,5	6	12,5

## RETAINER BOLT - ZUGBOLZENSATZ - GRUPPO TIRANTE

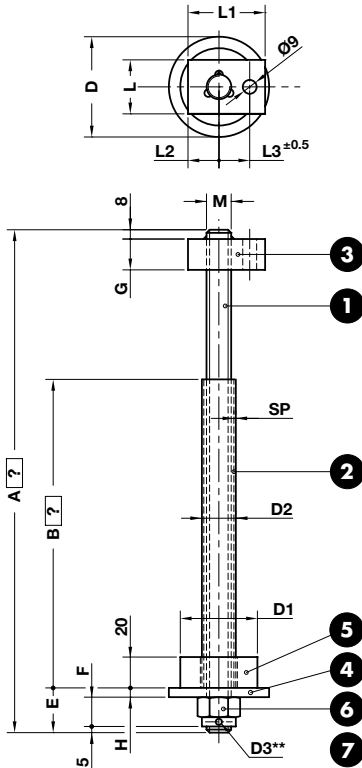

\*\* Drill hole in rod for copper pin at assembly  
 Bohrung für splint durchzuführen bei der montage  
 Foro per copiglia da eseguire al montaggio



⚠  
 Respect the max. load  
 Maximale Nutzlast beachten  
 Rispettare il carico max.

- ### Notes
- 1 **Material:** Thread rod cl 8.8
  - 2 3 **Material:** St37
  - 4 **Material:** CK45
  - 5 Elastomer 92SH
  - 6 DIN 935 cl. 8.8
  - 7 DIN 94

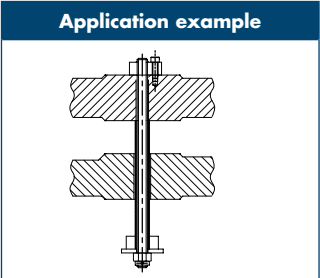

ORDER EXAMPLE	Art.	M=M30	A=100	B=60
	C13.20.	M30	100	60

OMCR CODE	D	D1	D2	D3	SP	E	F	G	H	L	L1	L2	L3	M	Max load (kN)
C13.20.	65	50	22	4	2,5	30	19	20	6	35	50	20	20	M16	2,5
C13.20.	82	63	25	4	2	35	22	20	8	40	50	20	20	M20	4,5
C13.20.	105	80	30	5	2,5	42	27	20	10	45	50	20	20	M24	7,5
C13.20.	130	100	38	6,3	3,5	50	33	25	12	50	63	28	26	M30	12,5



## GROUND COLLAR SCREW - SCHRAUBE MIT DISTANZROHR - VITE CON COLLETO

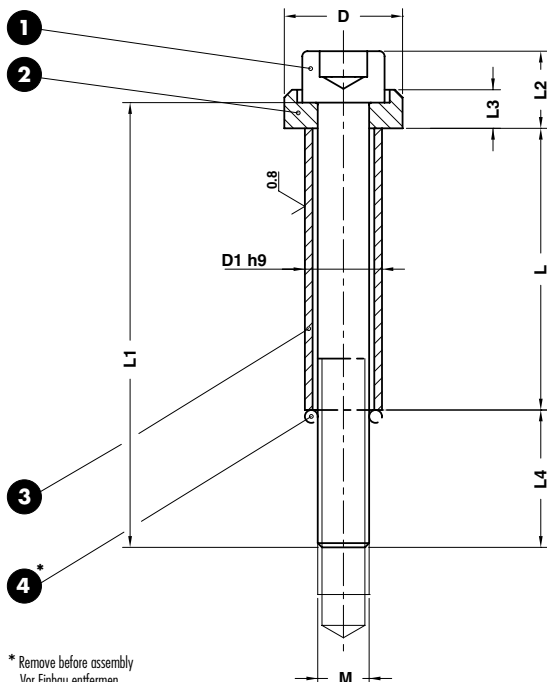

\* Remove before assembly  
Vor Einbau entfernen  
Da rimuovere prima del montaggio



### Notes

- 1 DIN 912 cl. 12.9
- 2 **Material:** Steel 1000 N/mm<sup>2</sup>
- 3 **Material:** Steel 1200-1400 N/mm<sup>2</sup>
- 4 O-Ring\*

### Application example

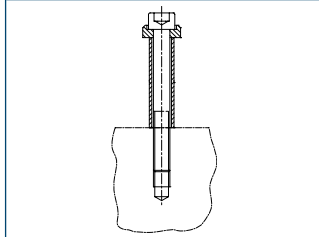

ORDER EXAMPLE	Art.	M=M6	L=70
	C13.24.	M06	070

OMCR CODE	D	D1	L	L1	L2	L3	L4	M
C13.24.M06020	15	10	20	35	10	5,5	11	M6
C13.24.M06025	15	10	25	40	10	5,5	11	M6
C13.24.M06030	15	10	30	45	10	5,5	11	M6
C13.24.M06035	15	10	35	50	10	5,5	11	M6
C13.24.M06040	15	10	40	55	10	5,5	11	M6
C13.24.M06045	15	10	45	60	10	5,5	11	M6
C13.24.M06050	15	10	50	65	10	5,5	11	M6
C13.24.M06055	15	10	55	70	10	5,5	11	M6
C13.24.M06060	15	10	60	80	10	5,5	16	M6
C13.24.M06070	15	10	70	90	10	5,5	16	M6
C13.24.M06080	15	10	80	100	10	5,5	16	M6
C13.24.M06090	15	10	90	110	10	5,5	16	M6
C13.24.M06100	15	10	100	120	10	5,5	16	M6
C13.24.M08030	19	12,5	30	45	13	6,5	10	M8
C13.24.M08035	19	12,5	35	50	13	6,5	10	M8
C13.24.M08040	19	12,5	40	55	13	6,5	10	M8
C13.24.M08045	19	12,5	45	60	13	6,5	10	M8

## GROUND COLLAR SCREW - SCHRAUBE MIT DISTANZROHR - VITE CON COLLETO

OMCR CODE	D	D1	L	L1	L2	L3	L4	M
C13.24.M08050	19	12,5	50	65	13	6,5	10	M8
C13.24.M08055	19	12,5	55	70	13	6,5	10	M8
C13.24.M08060	19	12,5	60	80	13	6,5	15	M8
C13.24.M08070	19	12,5	70	90	13	6,5	15	M8
C13.24.M08080	19	12,5	80	100	13	6,5	15	M8
C13.24.M08090	19	12,5	90	110	13	6,5	15	M8
C13.24.M08100	19	12,5	100	120	13	6,5	15	M8
C13.24.M10030	23	15	30	50	15	7,5	15	M10
C13.24.M10035	23	15	35	55	15	7,5	15	M10
C13.24.M10040	23	15	40	60	15	7,5	15	M10
C13.24.M10045	23	15	45	65	15	7,5	15	M10
C13.24.M10050	23	15	50	70	15	7,5	15	M10
C13.24.M10055	23	15	55	75	15	7,5	15	M10
C13.24.M10060	23	15	60	80	15	7,5	15	M10
C13.24.M10070	23	15	70	90	15	7,5	15	M10
C13.24.M10080	23	15	80	100	15	7,5	15	M10
C13.24.M10090	23	15	90	110	15	7,5	15	M10
C13.24.M10100	23	15	100	120	15	7,5	15	M10
C13.24.M10120	23	15	120	140	15	7,5	15	M10
C13.24.M12030	27	17,5	30	50	18	9	14	M12
C13.24.M12040	27	17,5	40	60	18	9	14	M12
C13.24.M12045	27	17,5	45	65	18	9	14	M12
C13.24.M12050	27	17,5	50	70	18	9	14	M12
C13.24.M12055	27	17,5	55	80	18	9	19	M12
C13.24.M12060	27	17,5	60	90	18	9	24	M12
C13.24.M12070	27	17,5	70	100	18	9	24	M12
C13.24.M12080	27	17,5	80	110	18	9	24	M12
C13.24.M12090	27	17,5	90	120	18	9	24	M12
C13.24.M12100	27	17,5	100	130	18	9	24	M12
C13.24.M12110	27	17,5	110	140	18	9	24	M12
C13.24.M12120	27	17,5	120	150	18	9	24	M12
C13.24.M12140	27	17,5	140	180	18	9	24	M12
C13.24.M16050	34	23	50	80	24	11	22	M16
C13.24.M16060	34	23	60	90	24	11	22	M16
C13.24.M16070	34	23	70	100	24	11	22	M16
C13.24.M16080	34	23	80	110	24	11	22	M16
C13.24.M16090	34	23	90	120	24	11	22	M16
C13.24.M16100	34	23	100	130	24	11	22	M16
C13.24.M16110	34	23	110	140	24	11	22	M16
C13.24.M16120	34	23	120	150	24	11	22	M16
C13.24.M16140	34	23	140	180	24	11	32	M16
C13.24.M16150	34	23	150	180	24	11	22	M16
C13.24.M16160	34	23	160	200	24	11	32	M16

## PAD RETAINER - HALTELEMENT - GRUPPO TIRANTE

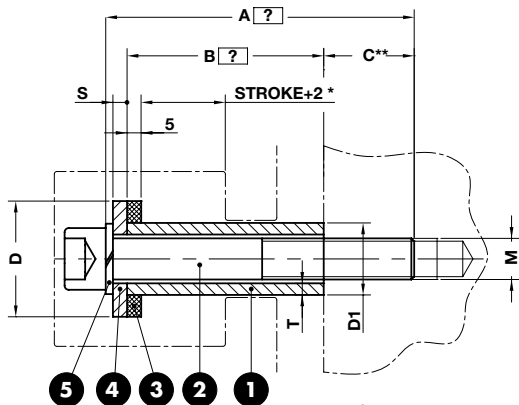

**⚠**  
 Respect the max. load  
 Maximale Nutzlast beachten  
 Rispettare il carico max.

- Notes**
- 1 Material:** St37
  - 2** DIN 912 cl. 8.8
  - 3 Material:** Elastomer 92SH
  - 4 Material:** CK45
  - 5** DIN 127



Art.	M=M10	A=100	B=76
C13.25.	M10	A100	B076

\* Hub +2, Corsa +2  
 \*\* 1,5 x d on steel, auf stahl, su acciaio  
 2 x d on cast iron, auf gusseisen, su ghisa

OMCR CODE	D	D1	M	S	T	Max load (kN)
C13.25.	32	16	M10	4	2,5	1
C13.25.	36	20	M12	6	3,5	1,5
C13.25.	45	28	M16	6	5,5	2,5

## PAD RETAINER - HALTELEMENT - GRUPPO TIRANTE

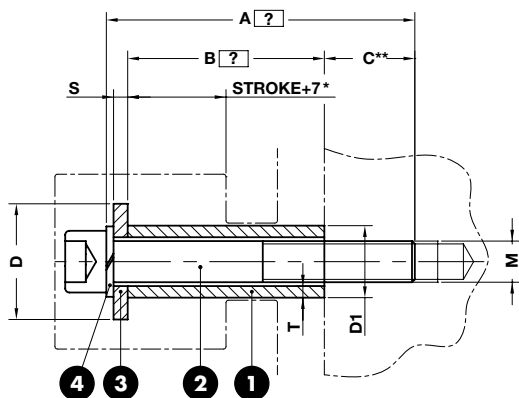

**⚠**  
 Respect the max. load  
 Maximale Nutzlast beachten  
 Rispettare il carico max.

- Notes**
- 1 Material:** St37
  - 2** DIN 912 cl. 8.8
  - 3 Material:** CK45
  - 4** DIN 127



Art.	M=M10	A=100	B=76
C13.26.	M10	A100	B076

\* Hub +7, Corsa +7  
 \*\* 1,5 x d on steel, auf stahl, su acciaio  
 2 x d on cast iron, auf gusseisen, su ghisa

OMCR CODE	D	D1	M	S	T	Max load (kN)
C13.26.	25	16	M10	4	2,5	1
C13.26.	30	20	M12	6	3,5	1,5
C13.26.	40	28	M16	6	5,5	2,5

## ANTI-REBOUND PAD RETAINER HALTELEMENT MIT DÄMPFUNG GRUPPO TIRANTE ANTIRIMBALZO

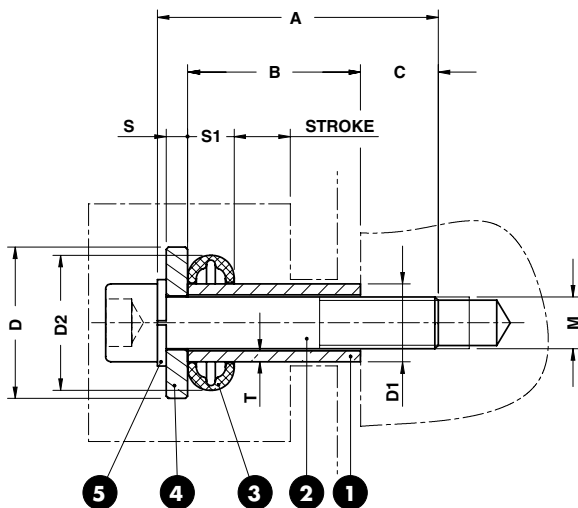

For dimensioning see pages 86-87  
Dimensionierung s. Seiten 86-87  
Per il dimensionamento vedi pagine 86-87



Respect the max. load  
Maximale Nutzlast beachten  
Rispettare il carico max.

- Notes**
- 1** Material: St37
  - 2** DIN 912 cl. 8.8
  - 3** C17.27
  - 4** Material: CK45
  - 5** DIN 127

ORDER EXAMPLE	Art.	M=M10	A=75	B=50
C13.27.	M10	075	050	

OMCR CODE	A	B	C	D	D1	D2	M	S	S1	T
C13.27.M10065040	65	40	18	30	16	26,4	M10	5	7,8	2,5
C13.27.M10075050	75	50	18	30	16	26,4	M10	5	7,8	2,5
C13.27.M10090063	90	63	20	30	16	26,4	M10	5	7,8	2,5
C13.27.M10130100	130	100	18	30	16	26,4	M10	5	7,8	2,5
C13.27.M12080050	80	50	23	35	20	32,1	M12	5	10,8	3,5
C13.27.M12090063	90	63	20	35	20	32,1	M12	5	10,8	3,5
C13.27.M12110080	110	80	23	35	20	32,1	M12	5	10,8	3,5
C13.27.M12130100	130	100	23	35	20	32,1	M12	5	10,8	3,5
C13.27.M16100063	100	63	28	50	25	45,8	M16	6	17,0	4
C13.27.M16120080	120	80	31	50	25	45,8	M16	6	17,0	4
C13.27.M16140100	140	100	31	50	25	45,8	M16	6	17,0	4
C13.27.M16160125	160	125	26	50	25	45,8	M16	6	17,0	4
C13.27.M20130080	130	80	38	65	30	54,6	M20	8	21,3	4
C13.27.M20170125	170	125	33	65	30	54,6	M20	8	21,3	4
C13.27.M24140080	140	80	45	70	36	61,8	M24	10	21,5	5
C13.27.M24160100	160	100	45	70	36	61,8	M24	10	21,5	5
C13.27.M24180125	180	125	40	70	36	61,8	M24	10	21,5	5
C13.27.M30160080	160	80	59	90	42	78,5	M30	15	29,4	5
C13.27.M30180100	180	100	59	90	42	78,5	M30	15	29,4	5
C13.27.M30200125	200	125	54	90	42	78,5	M30	15	29,4	5

Standard OMCR



## ANTI-REBOUND PAD RETAINER HALTELEMENT MIT DÄMPFUNG GRUPPO TIRANTE ANTIRIMBALZO

### EXAMPLE:

Pressure pad weight - Niederhaltergewicht - Massa del premilamiera: **500 daN**

Pressure pad speed - Niederhaltergeschwindigkeit - Velocità del premilamiera: **0,4 m/s**

Strokes/minute - Hübe/min - Corse/min.: **20**

Strokes/minute **18-25**

Pressure pad weight (daN)	Pressure pad speed (m/s)										
	0,1	0,2	0,3	0,4	0,5	0,6	0,7	0,8	0,9	1	1,1
100	2x M10	2x M10	2x M10	2x M12 4x M10	2x M12 5x M10	3x M12 7x M10	3x M12 9x M10	2x M16 4x M12	3x M16 5x M12	3x M16 6x M12	2x M20 4x M16
250	2x M10	3x M10	2x M12 5x M10	3x M12 8x M10	3x M16 4x M12	3x M16 6x M12	2x M20 4x M16	2x M20 5x M16	3x M20 6x M16	3x M20 8x M16	3x M24 4x M20
500	3x M10	3x M12 6x M10	3x M16 4x M12	3x M16 6x M12	3x M20 5x M16	3x M20 6x M16	3x M24 4x M20	3x M24 4x M20	3x M30 4x M24	3x M30 4x M24	4x M30 5x M24
750	3x M12	3x M16 5x M10	3x M16 6x M12	3x M16 5x M16	3x M20 7x M16	3x M20 4x M20	3x M24 5x M20	3x M24 4x M24	3x M30 5x M24	4x M30 6x M24	5x M30 7x M24
1000	3x M12 6x M10	3x M16 5x M12	3x M20 4x M16	3x M20 6x M16	3x M20 4x M20	3x M24 4x M24	3x M24 4x M24	3x M30 5x M24	4x M30 7x M24	5x M30 8x M24	6x M30 9x M24

- Nr.3 C13.27.M16 or nr.6 C13.27.M12
- 3 St. C13.27.M16 oder 6 St. C13.27.M12
- N.3 C13.27.M16 o n.6 C13.27.M12

### Strokes/minute ≤17

Pressure pad weight (daN)	Pressure pad speed (m/s)												
	0,1	0,2	0,3	0,4	0,5	0,6	0,7	0,8	0,9	1	1,1	1,2	1,3
100	2x M10	2x M10	2x M10	2x M12 4x M10	2x M12 5x M10	3x M12 7x M10	3x M12 9x M10	2x M16 4x M12	3x M16 5x M12	3x M16 6x M12	2x M20 4x M16	2x M20 4x M16	2x M20 5x M16
250	2x M10	3x M10	2x M12 5x M10	3x M12 8x M10	2x M16 4x M12	3x M16 6x M12	2x M20 4x M16	3x M20 5x M16	3x M20 6x M16	3x M24 4x M20	3x M24 5x M24	3x M24 6x M24	3x M24 4x M30
500	3x M10	3x M12 6x M10	3x M16 4x M12	3x M16 6x M12	3x M20 4x M16	3x M20 6x M16	3x M24 4x M20	3x M24 4x M20	3x M30 4x M24	3x M30 4x M24	3x M30 5x M24	3x M30 6x M24	4x M30 6x M24
750	3x M12	3x M16 5x M10	3x M16 6x M12	3x M16 5x M16	3x M20 6x M16	3x M20 4x M20	3x M24 5x M20	3x M24 4x M24	3x M30 5x M24	3x M30 6x M24	4x M30 7x M24	5x M30 8x M24	5x M30 9x M24
1000	3x M12 6x M10	3x M16 5x M12	3x M20 4x M16	3x M20 6x M16	3x M24 4x M20	3x M30 4x M24	3x M30 5x M24	3x M30 4x M24	4x M30 7x M24	4x M30 8x M24	5x M30 9x M24	6x M30 11x M24	7x M30 12x M24
1250	4x M12	4x M16 7x M10	4x M20 5x M16	4x M20 7x M16	4x M24 5x M20	4x M24 7x M20	4x M30 5x M24	4x M30 7x M24	5x M30 8x M24	5x M30 10x M24	6x M30 11x M24	7x M30	9x M30
1500	4x M12	4x M16 9x M10	4x M20 6x M16	4x M20 9x M16	4x M24 6x M20	4x M24 9x M24	4x M30 6x M24	4x M30 8x M24	5x M30 10x M24	5x M30 11x M24	6x M30	8x M30	9x M30
1750	4x M16	4x M16 5x M12	4x M20 7x M16	4x M24 5x M20	4x M30 5x M24	4x M30 6x M24	4x M30 7x M24	4x M30 9x M24	5x M30 11x M24	6x M30	7x M30	9x M30	10x M30
2000	4x M16	4x M20 6x M12	4x M24 8x M16	4x M24 6x M20	4x M30 5x M24	4x M30 7x M24	4x M30 8x M24	4x M30 10x M24	5x M30 6x M30	6x M30	7x M30	8x M30	10x M30
2500	4x M16	4x M20 7x M12	4x M24 6x M16	4x M30 5x M24	4x M30 6x M24	4x M30 8x M24	4x M30 10x M24	5x M30 6x M30	6x M30	7x M30	9x M30	10x M30	12x M30
3000	4x M16	4x M20 8x M12	4x M24 7x M16	4x M30 6x M24	4x M30 7x M24	4x M30 10x M24	5x M30 12x M24	6x M30	7x M30	9x M30	10x M30	12x M30	
3500	4x M20	4x M24 5x M16	4x M30 5x M20	4x M30 6x M24	4x M30 9x M24	5x M30 11x M24	7x M30	8x M30	10x M30	12x M30			
4000	4x M20	4x M24 6x M16	4x M30 6x M20	4x M30 7x M24	4x M30 10x M24	5x M30 7x M30	6x M30	7x M30	9x M30	11x M30			
4500	4x M20	4x M24 6x M16	4x M30 6x M20	4x M30 8x M24	4x M30 11x M24	5x M30	6x M30	7x M30	8x M30	10x M30			
5000	4x M24	4x M30 5x M20	4x M30 6x M24	6x M30 9x M24	7x M30 12x M24	9x M30	12x M30						
5500	4x M24	4x M30 5x M20	5x M30 7x M24	6x M30 10x M24	8x M30	10x M30							
6000	4x M24	4x M30 5x M20	5x M30 8x M24	7x M30 11x M24	9x M30	11x M30							



**Strokes/minute 18÷25**

Pressure pad weight (daN)	Pressure pad speed (m/s)												
	0,1	0,2	0,3	0,4	0,5	0,6	0,7	0,8	0,9	1	1,1	1,2	1,3
100	2x M10	2x M10	2x M10	2x M12 4x M10	2x M12 5x M10	3x M12 7x M10	3x M12 9x M10	2x M16 6x M12	3x M16 5x M12	3x M16 6x M12	2x M20 4x M16	2x M20 5x M16	2x M20 5x M16
250	2x M10	3x M10	2x M12 5x M10	3x M12 8x M10	3x M16 4x M12	3x M16 6x M12	2x M20 4x M16	2x M20 5x M16	3x M20 6x M16	3x M20 4x M20	3x M20 4x M20	3x M24 5x M20	3x M24 5x M20
500	3x M10	3x M12 6x M10	3x M16 4x M12	3x M16 6x M12	3x M20 5x M16	3x M20 6x M16	3x M24 4x M20	3x M24 4x M20	3x M30 4x M24	3x M30 4x M24	4x M30 4x M24	4x M30 5x M24	4x M30 6x M24
750	3x M12	3x M16 5x M10	3x M16 6x M12	3x M20 5x M16	3x M20 7x M16	3x M24 7x M16	3x M24 4x M20	3x M24 5x M20	3x M30 4x M24	3x M30 4x M24	4x M30 5x M24	4x M30 6x M24	4x M30 7x M24
1000	3x M12 6x M10	3x M16 5x M12	3x M20 4x M16	3x M20 6x M16	3x M24 4x M20	3x M30 4x M24	3x M30 4x M24	4x M30 5x M24	5x M30 6x M24	5x M30 7x M24	6x M30 8x M24	7x M30 9x M24	8x M30 11x M24
1250	4x M12 7x M10	4x M16 6x M12	4x M20 5x M16	4x M20 8x M16	4x M24 5x M20	4x M24 7x M20	4x M30 5x M24	4x M30 7x M24	5x M30 8x M24	5x M30 10x M24	6x M30 11x M24	7x M30 11x M24	8x M30 12x M24
1500	4x M12 9x M10	4x M16 7x M12	4x M20 6x M16	4x M24 5x M20	4x M24 6x M20	4x M30 5x M24	4x M30 6x M24	4x M30 8x M24	5x M30 8x M24	6x M30 10x M24	7x M30 11x M24	8x M30 11x M24	8x M30 12x M24
1750	4x M16 5x M12	4x M16 8x M12	4x M20 7x M16	4x M24 5x M20	4x M30 5x M24	4x M30 6x M24	4x M30 7x M24	4x M30 9x M24	5x M30 11x M24	6x M30 10x M30	7x M30 12x M30	8x M30 12x M30	8x M30 12x M30
2000	4x M16 6x M12	4x M20 5x M16	4x M20 8x M16	4x M24 6x M20	4x M30 5x M24	4x M30 7x M24	4x M30 8x M24	4x M30 10x M24	5x M30 9x M30	6x M30 11x M30	7x M30 11x M30	8x M30 11x M30	8x M30 11x M30
2500	4x M16 7x M12	4x M20 6x M16	4x M24 5x M20	4x M24 5x M24	4x M30 6x M24	4x M30 8x M24	4x M30 10x M24	4x M30 10x M24	5x M30 11x M30	6x M30 12x M30	7x M30 12x M30	8x M30 12x M30	8x M30 12x M30
3000	4x M16 8x M12	4x M20 7x M16	4x M24 6x M20	4x M24 6x M24	4x M30 7x M24	4x M30 10x M24	4x M30 12x M24	4x M30 12x M24	5x M30 11x M30	6x M30 12x M30	7x M30 12x M30	8x M30 12x M30	8x M30 12x M30
3500	4x M20 5x M16	4x M24 5x M20	4x M30 5x M24	4x M30 6x M24	5x M30 7x M24	5x M30 9x M24	6x M30 11x M30	6x M30 11x M30	7x M30 11x M30	8x M30 11x M30	9x M30 11x M30	9x M30 11x M30	9x M30 11x M30
4000	4x M20 6x M16	4x M24 6x M20	4x M30 5x M24	4x M30 6x M24	5x M30 7x M24	5x M30 10x M24	6x M30 12x M30	6x M30 12x M30	7x M30 12x M30	8x M30 12x M30	9x M30 12x M30	9x M30 12x M30	9x M30 12x M30
4500	4x M20 6x M16	4x M24 6x M20	4x M30 6x M24	4x M30 8x M24	5x M30 11x M24	6x M30 11x M30	7x M30 11x M30	8x M30 11x M30	9x M30 11x M30	10x M30 11x M30	11x M30 11x M30	12x M30 11x M30	12x M30 11x M30
5000	4x M24 5x M20	4x M30 5x M24	4x M30 6x M24	4x M30 9x M24	5x M30 12x M24	6x M30 12x M30	7x M30 12x M30	8x M30 12x M30	9x M30 12x M30	10x M30 12x M30	11x M30 12x M30	12x M30 12x M30	12x M30 12x M30
5500	4x M24 5x M20	4x M30 5x M24	4x M30 7x M24	4x M30 10x M24	5x M30 10x M30	6x M30 10x M30	7x M30 10x M30	8x M30 10x M30	9x M30 10x M30	10x M30 10x M30	11x M30 10x M30	12x M30 10x M30	12x M30 10x M30
6000	4x M24 6x M20	4x M30 5x M24	4x M30 8x M24	4x M30 11x M24	5x M30 11x M30	6x M30 10x M30	7x M30 10x M30	8x M30 10x M30	9x M30 10x M30	10x M30 10x M30	11x M30 10x M30	12x M30 10x M30	12x M30 10x M30

Standard OMCR

**Strokes/minute 26÷40**

Pressure pad weight (daN)	Pressure pad speed (m/s)												
	0,1	0,2	0,3	0,4	0,5	0,6	0,7	0,8	0,9	1	1,1	1,2	1,3
100	2x M10	2x M10	2x M10	2x M12 4x M10	2x M12 5x M10	3x M12 7x M10	3x M12 9x M10	2x M16 4x M12	3x M16 5x M12	3x M16 6x M12	3x M20 4x M16	3x M20 5x M16	2x M24 4x M20
250	2x M10	3x M10	2x M12 5x M10	3x M12 8x M10	3x M16 5x M12	3x M16 6x M12	3x M20 4x M16	2x M24 5x M20	3x M24 4x M20	3x M24 4x M20	3x M24 5x M20	4x M30 5x M24	4x M30 5x M24
400	3x M10	2x M12 5x M10	3x M12 8x M10	3x M16 5x M12	3x M20 4x M16	2x M24 5x M20	3x M24 4x M20	3x M30 5x M24	3x M30 4x M20	3x M30 4x M20	4x M30 5x M24	5x M30 6x M24	6x M30 8x M24
550	3x M10	3x M12 6x M10	3x M16 4x M12	3x M20 4x M16	3x M24 5x M20	3x M30 4x M24	3x M30 5x M24	3x M30 6x M24	4x M30 5x M24	4x M30 6x M24	5x M30 7x M24	6x M30 8x M24	7x M30 9x M24
700	3x M12	3x M16 4x M10	3x M16 5x M12	3x M20 4x M16	3x M24 5x M20	3x M30 4x M24	3x M30 5x M24	4x M30 6x M24	4x M30 7x M24	5x M30 8x M24	6x M30 10x M24	7x M30 12x M24	8x M30 12x M24
850	3x M12	3x M16 5x M10	3x M20 4x M16	3x M24 4x M20	3x M24 5x M20	4x M30 5x M24	4x M30 6x M24	4x M30 7x M24	5x M30 8x M24	6x M30 9x M24	7x M30 10x M24	8x M30 12x M24	9x M30 12x M30
1000	3x M12	3x M16 6x M10	3x M20 4x M16	3x M24 5x M20	3x M30 4x M24	4x M30 5x M24	4x M30 6x M24	5x M30 7x M24	6x M30 8x M24	7x M30 9x M24	8x M30 11x M30	9x M30 12x M30	9x M30 12x M30
1150	3x M16	3x M16 4x M12	3x M24 4x M20	3x M24 5x M20	4x M30 4x M24	5x M30 6x M24	6x M30 7x M24	7x M30 8x M24	8x M30 9x M24	9x M30 11x M30	10x M30 12x M30	12x M30 12x M30	12x M30 12x M30
1300	4x M12	4x M16 7x M10	4x M20 6x M12	4x M24 6x M20	4x M24 5x M24	4x M30 7x M24	5x M30 8x M24	6x M30 10x M24	7x M30 12x M24	8x M30 12x M24	9x M30 12x M24	10x M30 12x M24	11x M30 12x M24
1450	4x M12	4x M16 8x M10	4x M24 5x M20	4x M24 7x M20	4x M30 6x M24	4x M30 7x M24	5x M30 9x M24	6x M30 12x M24	7x M30 12x M24	8x M30 12x M24	9x M30 12x M24	10x M30 12x M24	11x M30 12x M24
1600	4x M16	4x M16 5x M12	4x M24 5x M20	4x M24 7x M20	4x M30 6x M24	4x M30 8x M24	5x M30 10x M24	6x M30 12x M24	7x M30 12x M24	8x M30 12x M24	9x M30 12x M24	10x M30 12x M24	11x M30 12x M24
1850	4x M16	4x M20 5x M12	4x M24 6x M20	4x M30 5x M24	4x M30 7x M24	5x M30 9x M24	6x M30 12x M24	7x M30 12x M24	8x M30 12x M24	9x M30 12x M24	10x M30 12x M24	11x M30 12x M24	12x M30 12x M24
2000	4x M16	4x M20 6x M12	4x M24 6x M20	4x M30 5x M24	4x M30 7x M24	5x M30 10x M24	6x M30 12x M24	7x M30 12x M24	8x M30 12x M24	9x M30 12x M24	10x M30 12x M24	11x M30 12x M24	12x M30 12x M24
2150	4x M16	4x M20 6x M12	4x M24 5x M16	4x M30 6x M24	4x M30 8x M24	5x M30 10x M24	6x M30 12x M24	7x M30 12x M24	8x M30 12x M24	9x M30 12x M24	10x M30 12x M24	11x M30 12x M24	12x M30 12x M24
2300	4x M16	4x M24 7x M12	4x M24 5x M20	4x M30 6x M24	4x M30 7x M24	5x M30 9x M24	6x M30 11x M30	7x M30 11x M30	8x M30 11x M30	9x M30 11x M30	10x M30 11x M30	11x M30 11x M30	12x M30 11x M30
2450	4x M16	4x M24 7x M12	4x M30 5x M20	4x M30 7x M24	5x M30 9x M24	6x M30 12x M24	7x M30 12x M24	8x M30 12x M24	9x M30 12x M24	10x M30 12x M24	11x M30 12x M24	12x M30 12x M24	12x M30 12x M24
2600	4x M16	4x M24 7x M12	4x M30 5x M20	4x M30 7x M24	5x M30 9x M24	6x M30 12x M24	7x M30 12x M24	8x M30 12x M24	9x M30 12x M24	10x M30 12x M24	11x M30 12x M24	12x M30 12x M24	12x M30 12x M24



COLLAR SCREW - SCHULTER-PASSSCHRAUBE - VITE CON COLLETTA

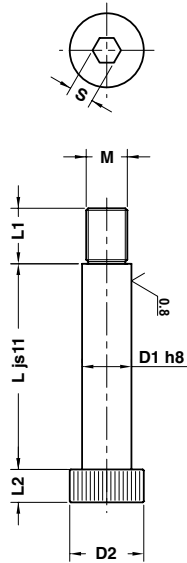

**Notes**  
**Material:** Steel cl. 12.9

ORDER EXAMPLE 	Art.	D1=6	L=10
	C13.30.	06	010

M	M5	M6	M8	M10	M12	M16	M20
D1	6	8	10	12	16	20	24
D2	10	13	16	18	24	30	36
L1	9,5	11	13	16	18	22	27
L2	4,5	5,5	7	9	11	14	16
S	3	4	5	6	8	10	12

L							
10	•	•					
12	•	•					
15	•	•	•	•			
16	•	•	•	•			
20	•	•	•	•			
25	•	•	•	•			
30	•	•	•	•	•		
35	•	•	•	•	•		
40	•	•	•	•	•	•	
45	•	•	•	•	•	•	
50	•	•	•	•	•	•	•
55	•	•	•	•	•	•	•
60	•	•	•	•	•	•	•
65		•	•	•	•	•	•
70		•	•	•	•	•	•
80		•	•	•	•	•	•
90		•	•	•	•	•	•
100		•	•	•	•	•	•
120			•	•	•	•	•

## KEY - PASSFEDER - CHIAVETTA DI REAZIONE

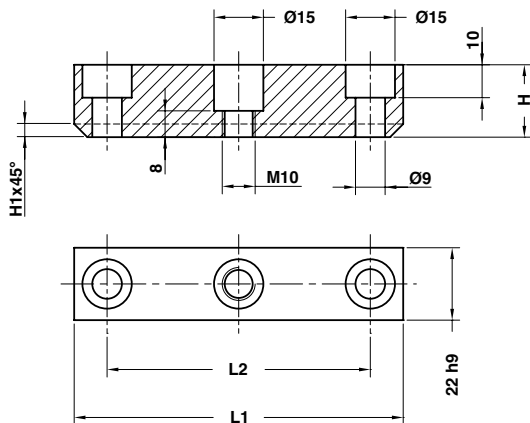

### Notes

**Material:** CK45

Standard OMCR

	Art.	H=14	L1=50
	C14.09.	14	050

OMCR CODE	H	H1	L1	L2
C14.09.14050	14	-	50	32
C14.09.14080	14	-	80	50
C14.09.14100	14	-	100	80
C14.09.14125	14	-	125	100
C14.09.22050	22	4	50	32
C14.09.22080	22	4	80	50
C14.09.22100	22	4	100	80
C14.09.22125	22	4	125	100
C14.09.40050	40	4	50	32
C14.09.40080	40	4	80	50
C14.09.40100	40	4	100	80
C14.09.40125	40	4	125	100

## KEY - PASSFEDER - CHIAVETTA DI REAZIONE

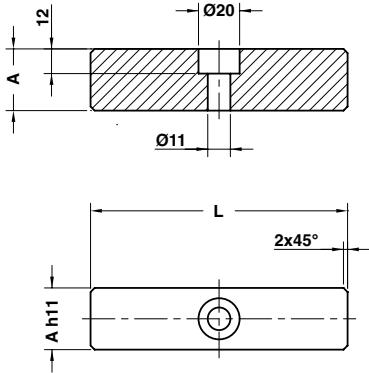

STOCK

3D  
WEB



### Notes

**Material:** CK45

ORDER EXAMPLE	Art.	A=25	L=80
	C14.10.	25	080

OMCR CODE	A	L
C14.10.25080	25	80
C14.10.25125	25	125
C14.10.30080	30	80
C14.10.30125	30	125

# C14.11

## RETAINER - HALTESTÜCK - RITEGNO PER MATRICE

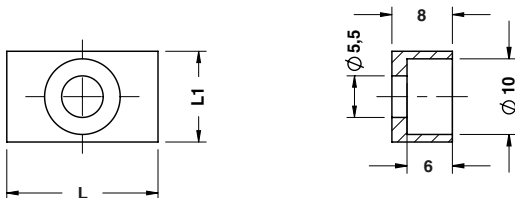

STOCK

3D  
WEB



### Notes

**Material:** CK45

ORDER EXAMPLE	Art.	L1=12	L=20
	C14.11.	12	20

OMCR CODE	L1	L
C14.11.1220	12	20
C14.11.1620	16	20

**KEY - PASSFEDER - CHIAVETTA DI REAZIONE**

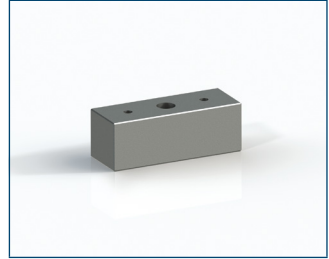
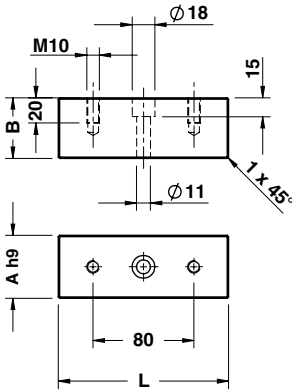

**Notes**

**Material:** CK45

Standard OMCR

	Art.	A=50	L=135
	C14.20.	50	135

OMCR CODE	A	B	L
C14.20.42125	42	40	125
C14.20.50135	50	48	135
C14.20.50220	50	48	220

## KEY - PASSFEDER - CHIAVETTA DI REAZIONE

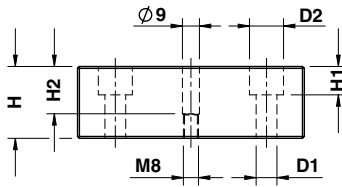

**TYPE 01**

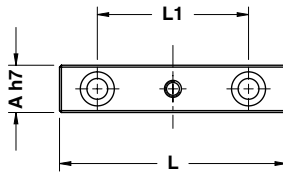

**TYPE 02**

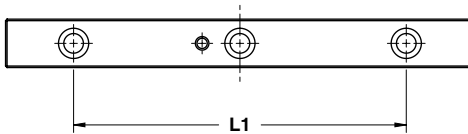

### Notes

**Material:** CK45

	Art.	A=25	H=38	L=120
	C14.25.	25	38	120

OMCR CODE	A	D1	D2	H	H1	H2	L	L1	TYPE
C14.25.2538090	25	11	18	38	15	25	90	50	01
C14.25.2538120	25	11	18	38	15	25	120	80	01
C14.25.3248150	32	13	20	48	25	35	150	90	01
C14.25.3248210	32	13	20	48	25	35	210	130	01
C14.25.3258260	32	13	20	58	25	42	260	150	01
C14.25.3258310	32	13	20	58	25	42	310	220	02
C14.25.3258350	32	13	20	58	25	42	350	250	02

KEY - PASSFEDER - CHIAVETTA

Standard OMCR

TYPE 01

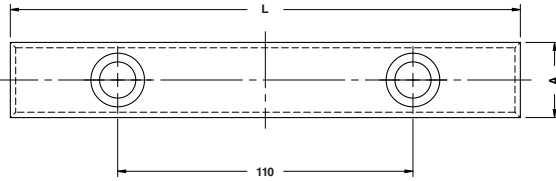

**Notes**  
**Material:** CK45

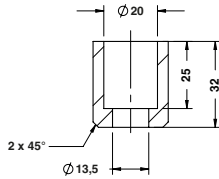

TYPE 10

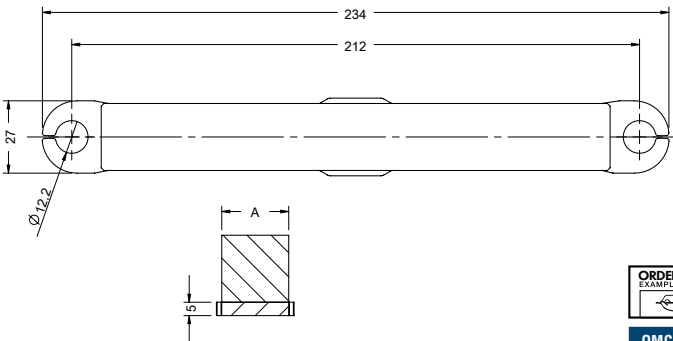
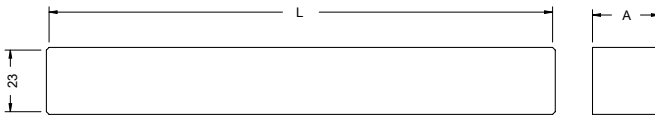

ORDER SAMPLE	Art.	TYPE
	C14.28.	10

OMCR CODE	L	A	TYPE
C14.28.01	190	28	01
C14.28.10	188	25	10

## LOCATING BLOCK - FANGBACKE - TASSELLO DI CENTRAGGIO

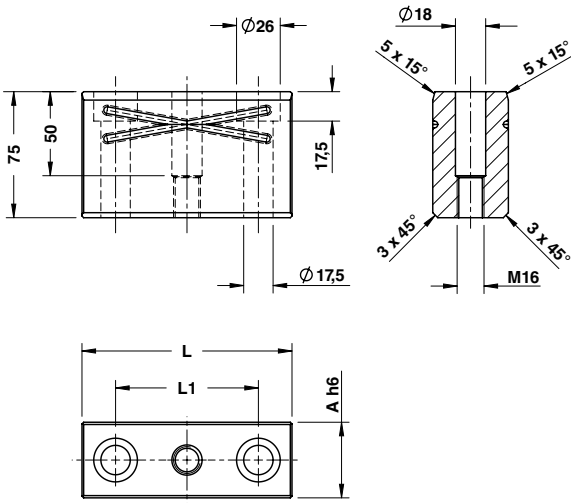

**Notes**

**Material:** 16MnCr5 - **HRC:** 60±62

	Art.	A=45	L=125
	C14.30.	45	125

OMCR CODE	A	L	L1
C14.30.45100	45	100	60
C14.30.45125	45	125	85
C14.30.45160	45	160	120
C14.30.45200	45	200	160



## CLAMP - BEFESTIGUNGSELEMENT - MORSETTO

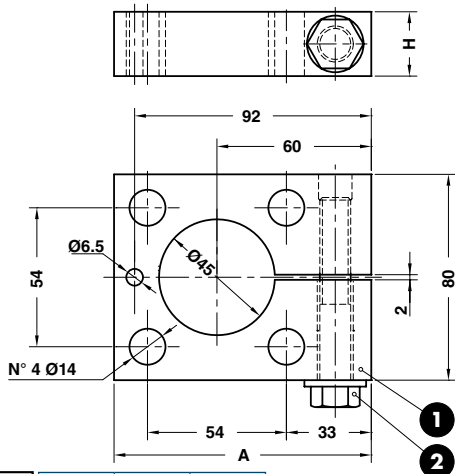

STOCK



WEB

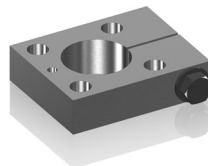

### Notes

- 1 Material: CK45
- 2 M12 x 70 DIN 931

### Application example

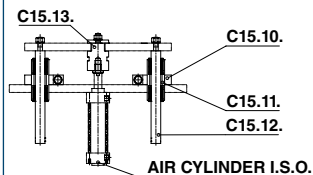

Art.	A=100	H=25
C15.10.	100	25

OMCR CODE	A	H
C15.10.10025	100	25

# C15.11

## SLEEVE - FÜHRUNGSEINHEIT - CANOTTO GUIDA

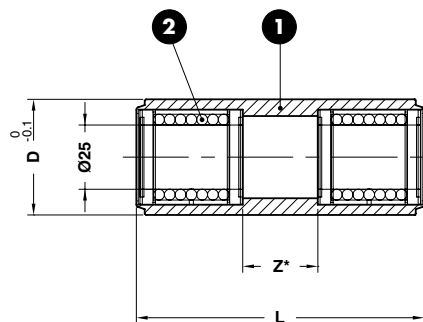

STOCK



WEB



### Notes

- 1 Material: CK45
- 2 Material: STAR 0658-225-40

### Application example

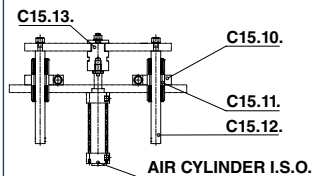

Art.	D=45	L=112
C15.11.	45	112

OMCR CODE	D	L	Z
C15.11.45112	45	112	40
C15.11.45200	45	200	120

\* Fixing zone  
Befestigungsbereich Klammer  
Zona di fissaggio

## GUIDE POST - FÜHRUNGSSAULE - COLONNA

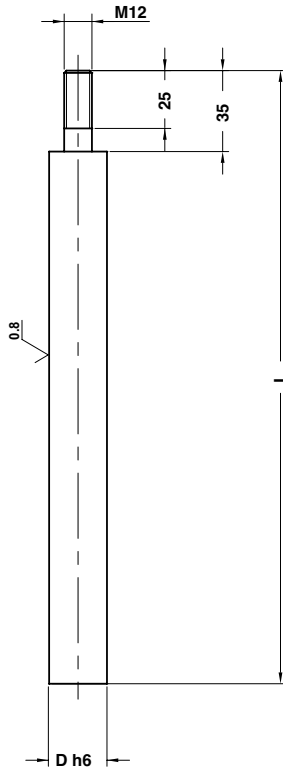

### Notes

**Material:** CK45  
**HRC:** 60÷62

### Application example

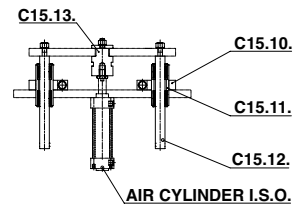

Art.	D=25	L=265
C15.12.	25	265

OMCR CODE	D	L
C15.12.25265	25	265
C15.12.25350	25	350
C15.12.25400	25	400
C15.12.25450	25	450
C15.12.25500	25	500

## UNION NUT - BEFESTIGUNGSELEMENT - DADO DI UNIONE

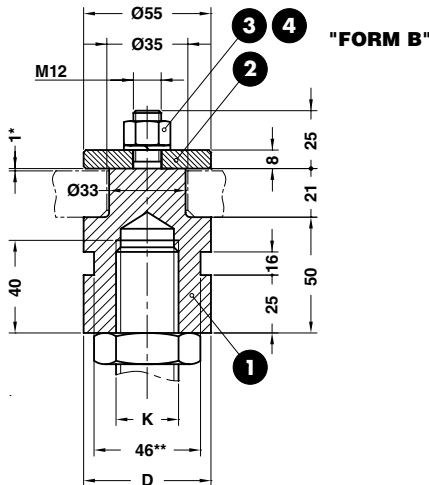
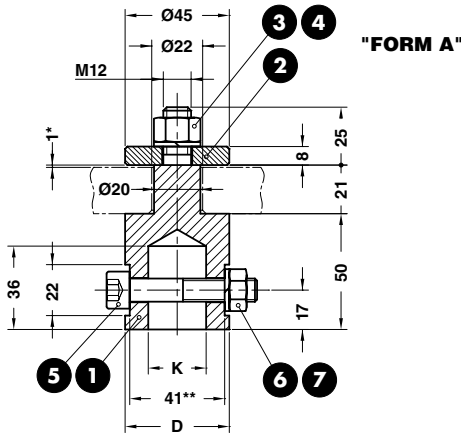

\* Backlash  
Spiel  
Gioco

\*\* Spanner  
Schlüssel  
Chiave

\*\*\* Rackwork  
Zahnstange-antreib  
Sollervatore a cremagliera



### Notes

- 1 2 Material: CK45
- 3 M12 DIN 934
- 4 Ø12 DIN 127B
- 5 M10X55 DIN 912
- 6 M10 DIN 934
- 7 Ø10 DIN 127B

### Application example FORM A

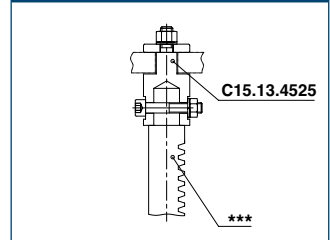

### Application example FORM B

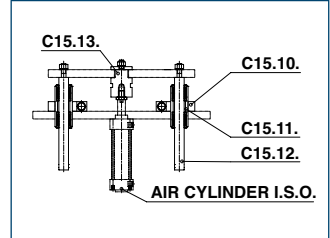

ORDER EXAMPLE	Art.	D=45	K=25
	C15.13.	45	25

OMCR CODE	D	K	FORM
C15.13.4525	45	25	A
C15.13.5516	55	M16x1,5	B
C15.13.5520	55	M20x1,5	B
C15.13.5527	55	M27x2	B

**AIR COUPLING BRACKET - LUFTANSCHLUSSBLOCK - SUPPORTO INNESTI RAPIDI**

**"FORM A"**

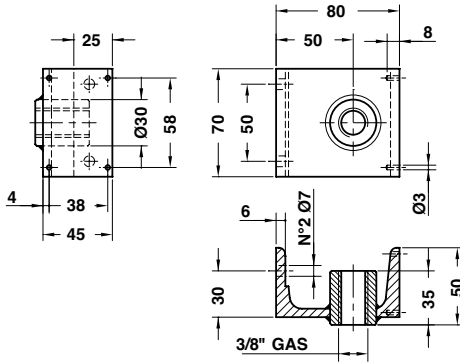

**"FORM B"**

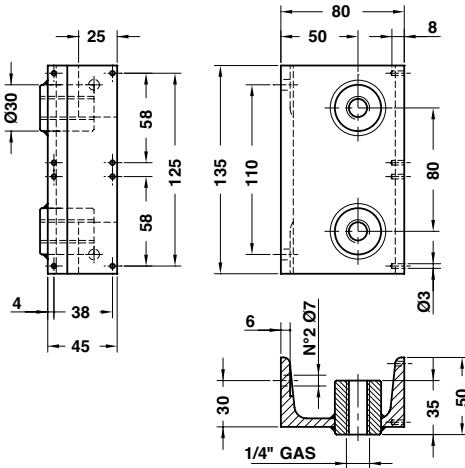

**Notes**  
**Material:** Si37

ORDER EXAMPLE	Art.	FORM
	C15.14.	A

OMCR CODE	FORM
C15.14.	A
C15.14.	B

FLUX CONTROL - VERTEILERBLOCK - REGOLATORE DI FLUSSO

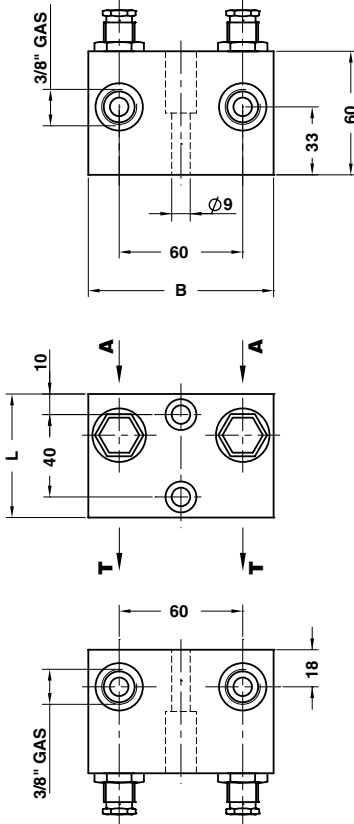
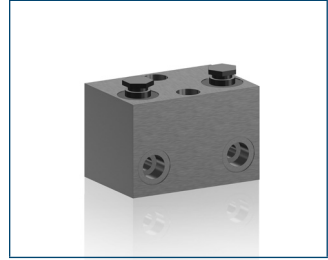

**Notes**  
**Material:** CK45

ORDER EXAMPLE	Art.	A=60	B=90
	C15.15.	60	90

OMCR CODE	A	B
C15.15.6090	60	90

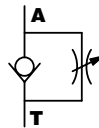

Standard OMCR

ROLLER - ROLLE - ROTELLA

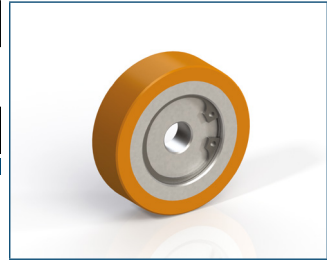
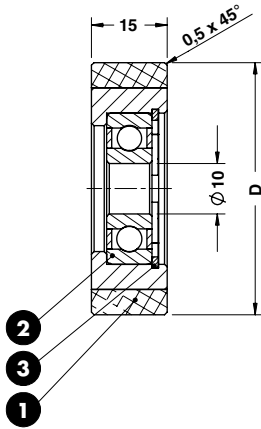

Notes

- 1 **Material:** Steel+Vulkolan
- 2 Roller Bearing 6200 2RS
- 3 130 DIN472



Art.	D=50
C16.18.	50

OMCR CODE	D	Max Load (daN)
C16.18.	50	70

ROLLER - ROLLE - ROTELLA

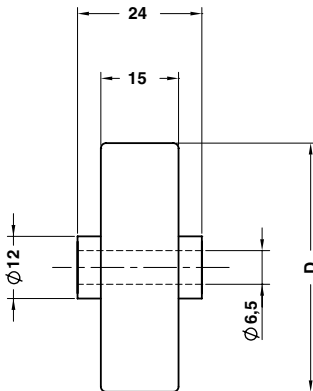

Notes

**Material:** Steel



Art.	D=48
C16.19.	48

OMCR CODE	D	Max Load (daN)
C16.19.	48	25

ROLLER STOCK LIFTER - FEDERENDE LAUFROLLE - RULLINO SOLLEVAMENTO NASTRO

TYPE 01

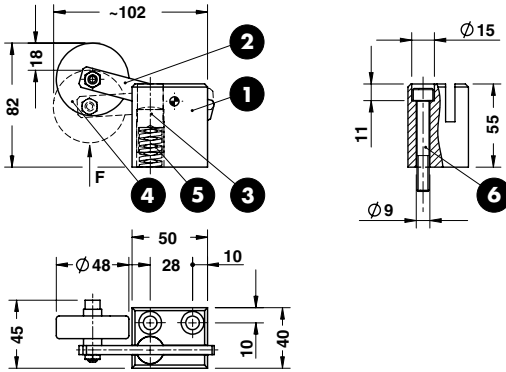

TYPE 02

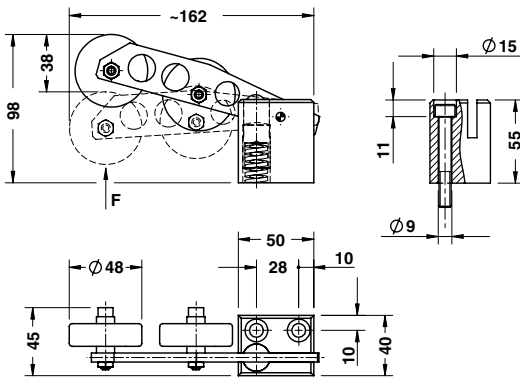

TYPE 03

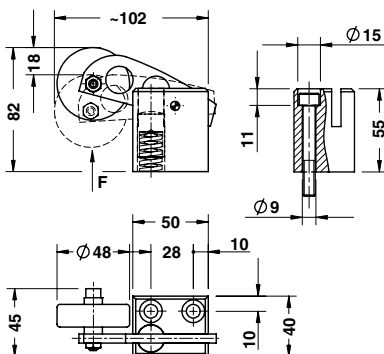

Notes

- 1 Material: C15
- 2 Material: S235JRG2K
- 3 Material: 42CrMo4
- 4 C16.19.48
- 5 Spring
- 6 Screws M8x60 DIN 912

ORDER EXAMPLE	Art.	TYPE
	C16.20.	01

OMCR CODE	F (N)	TYPE
C16.20.01	66	01
C16.20.02	32	02
C16.20.03	66	03
C16.20.04	66	04

TYPE 04

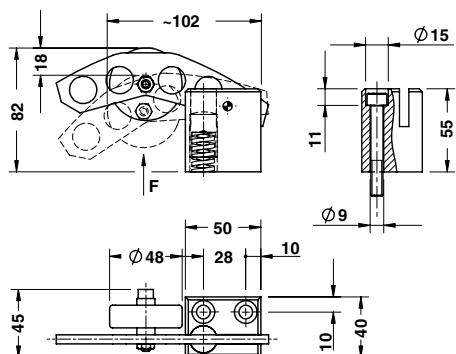

ROLLER STOCK LIFTER - FEDERINDE LAUFROLLE - RULLINO SOLLEVAMENTO NASTRO

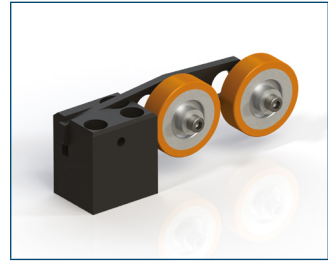
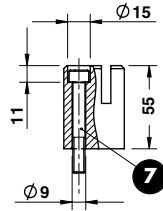
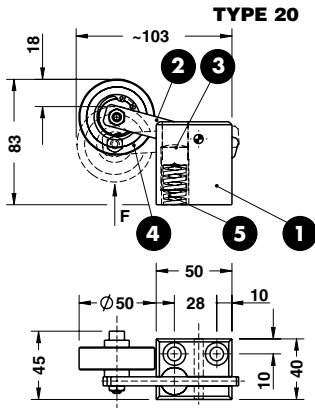

Notes

- 1 Material: C15
- 2 Material: S235JRG2K
- 3 Material: 42CrMo4
- 4 C16.18.50
- 5 Spring
- 6 Material: steel
- 7 Screws M8x60 DIN 912

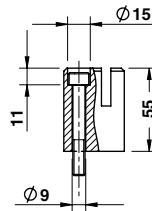
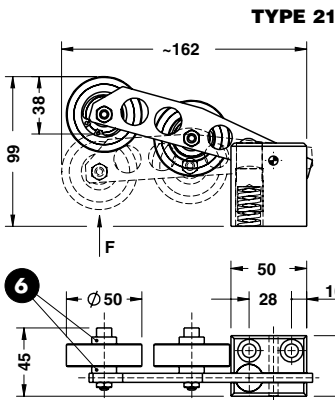

ORDER EXAMPLE	Art.	TYPE
	C16.20.	20

OMCR CODE	F (N)	TYPE
C16.20.20	66	20
C16.20.21	32	21
C16.20.22	66	22
C16.20.23	66	23

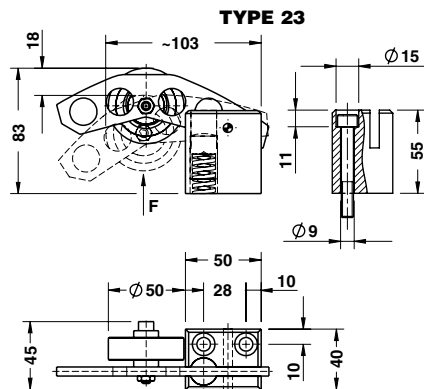
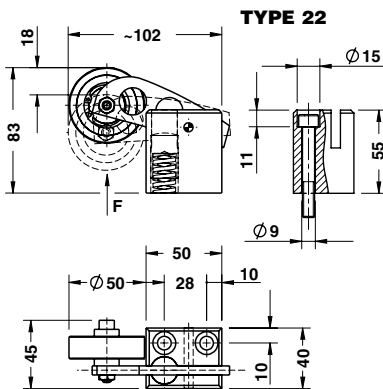



ROLLER GROUP - FÖRDERROLLE - GRUPPO RULLINI

Standard OMCR

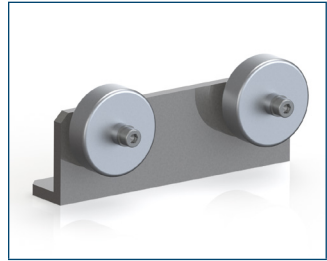
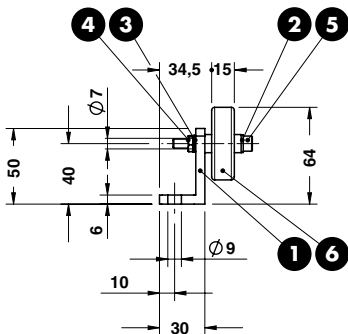
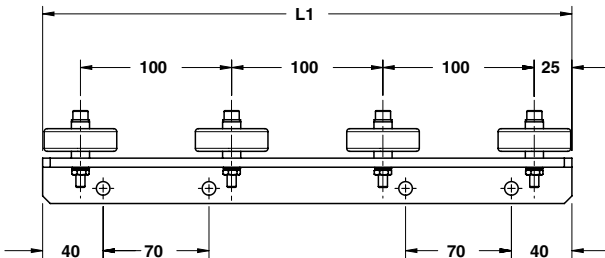
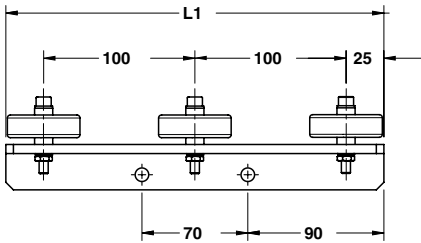
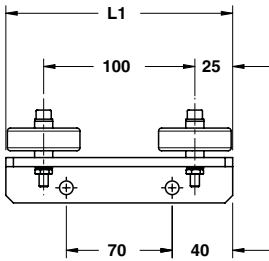

**Notes**

- 1 Material: St37
- 2 3 Washers for M6
- 4 Nut for M6
- 5 Screw M6x40 DIN 912
- 6 Material: Steel - C16.19.48

ORDER EXAMPLE	Art.	L1
	C16.21.	150
OMCR CODE	L1	Max Load (daN)
C16.21.150	150	50
C16.21.250	250	75
C16.21.350	350	100

## COIL SUPPORT - ABSTREIFER - SOLLEVATORE NASTRO

### Notes

- 1** Material: CK45
- 2** Material: Bronze - HB>190
- 3** SPRING
- 4** M6x8 DIN 913
- 5** Ø12x60 DIN 6325

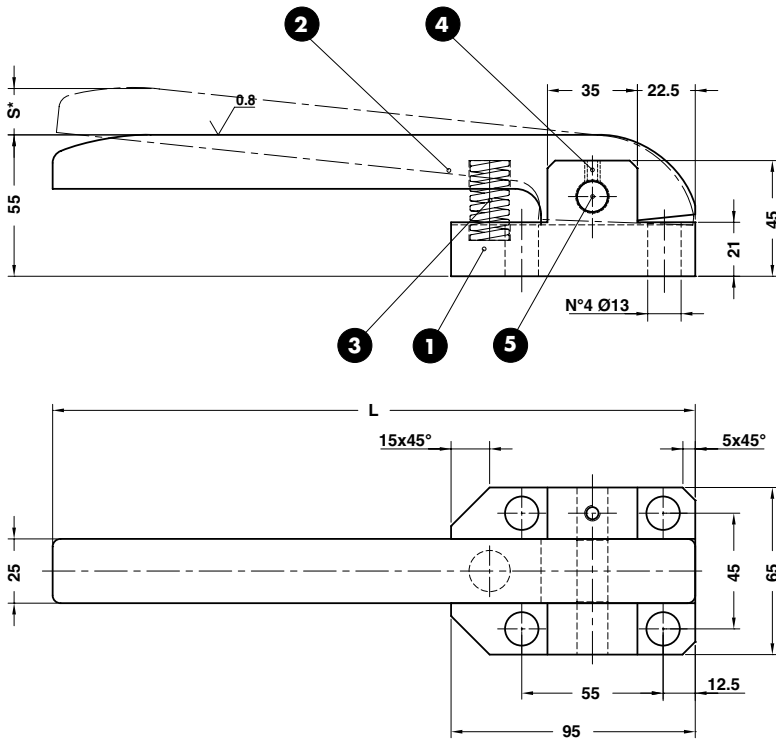
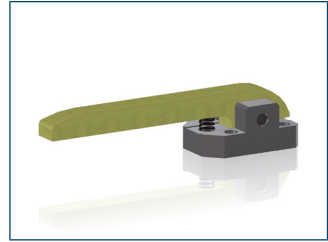

ORDER EXAMPLE	Art.	TYPE
	C16.25.	01

OMCR CODE	L	S	Spring	Spring initial force (daN)	Spring final force (daN)	TYPE
C16.25.01	250	18	TV016044	7,9 N	12,3 N	01
C16.25.02	250	18	B16044	27 N	42 N	02
C16.25.03	300	30	B16044	24 N	42 N	03

BALL CASTER - KUGELROLLENSYSTEM - SFERA PORTANTE

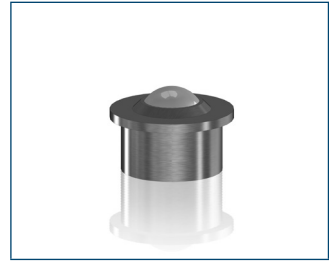
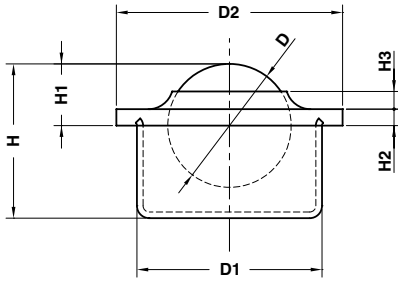

**Notes**  
**Material:** Steel

Standard OMCR

ORDER EXAMPLE	Art.	D=15
	C16.26.	15

OMCR CODE	D	D1	D2	Max load (daN)	H	H1	H2	H3
C16.26.15	15	24±0,065	31	50	21,5	9,5±0,2	2,8	3,5
C16.26.30	30	45±0,080	55	250	37,5	13,8±0,3	4	4,3

COIL GUIDE ROLLER - FÜHRUNGSROLLE - GUIDA NASTRO

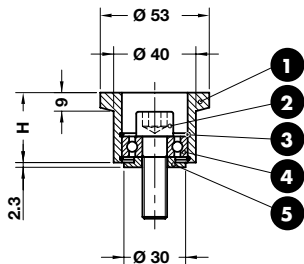

TYPE 01

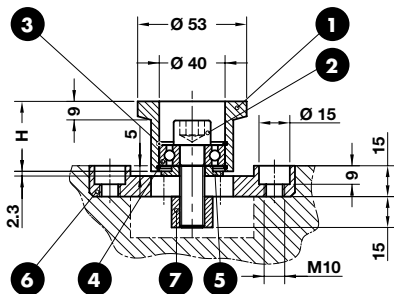

TYPE 02

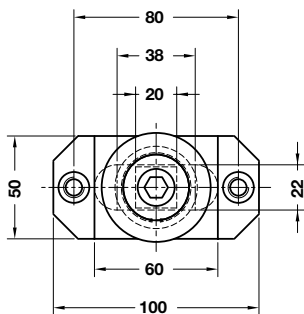

TYPE 01



**Notes TYPE 01**

- 1 Material: 16MnCr5 - HRC: 55÷58
- 2 M12x40 DIN 472
- 3 I32 DIN 472
- 4 6201 2Z VA DIN 625
- 5 Material: CK45

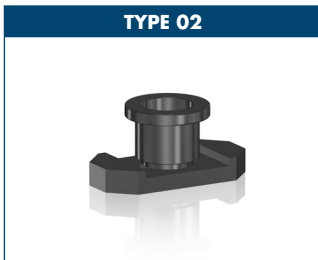

TYPE 02



**Notes TYPE 02**

- 1 Material: 16MnCr5 - HRC: 55÷58
- 2 M12x40 DIN 472
- 3 I32 DIN 472
- 4 6201 2Z VA DIN 625
- 5 Material: CK45
- 6 Material: St37
- 7 Material: CK45

ORDER EXAMPLE	Art.	TYPE	H=34
	C16.27.	01	34

OMCR CODE	TYPE	H
C16.27.0117	01	17
C16.27.0134	01	34
C16.27.0154	01	54
C16.27.0180	01	80
C16.27.0217	02	17
C16.27.0234	02	34
C16.27.0254	02	54
C16.27.0280	02	80

## FLANGE LIFTER - ABSTREIFER - SFLANGIATORE



Do not exceed the stroke  
Hub nicht überschreiten  
Non superare la corsa

### Notes

- 1** Material: EN-GJL300
- 2** Material: Bronze + Graphite - HB>190
- 3** Material: 36NiCrMo4
- 4** M8x25 DIN 912
- 5** Schnorr Ø8
- 6** Gas Spring
- 7** M6x12 DIN 7991



STOCK



WEB

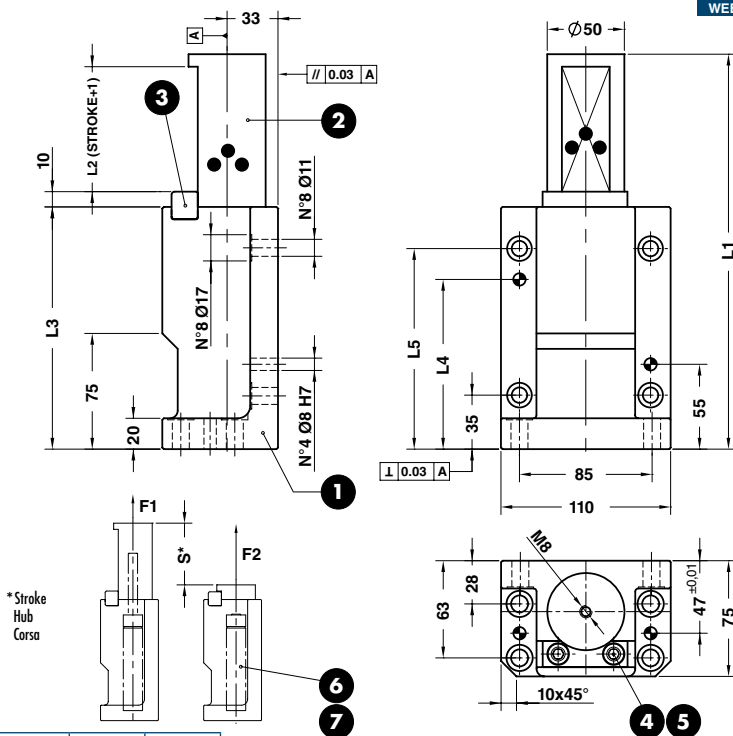

Art.	S=50	F1=50
C16.30.	50	050

OMCR CODE	F1 (daN)	F2 (daN)	L1	L2	L3	L4	L5	S
C16.30.50050	50	86	196	51	127	80	100	50
C16.30.50100	100	172	196	51	127	80	100	50
C16.30.50150	150	258	196	51	127	80	100	50
C16.30.50200	200	344	196	51	127	80	100	50
C16.30.80050	50	86	256	81	157	110	130	80
C16.30.80100	100	172	256	81	157	110	130	80
C16.30.80150	150	258	256	81	157	110	130	80
C16.30.80200	200	344	256	81	157	110	130	80

## FLANGE LIFTER - ABSTREIFER - SFLANGIATORE



Do not exceed the stroke  
Hub nicht überschreiten  
Non superare la corsa

### Notes

- 1 **Material:** EN-GJL300
- 2 **Material:** Bronze + Graphite - HB>190
- 3 **Material:** 36NiCrMo4
- 4 M8x25 DIN 912
- 5 Schnorr Ø8
- 6 Gas Spring
- 7 M6x12 DIN 7991

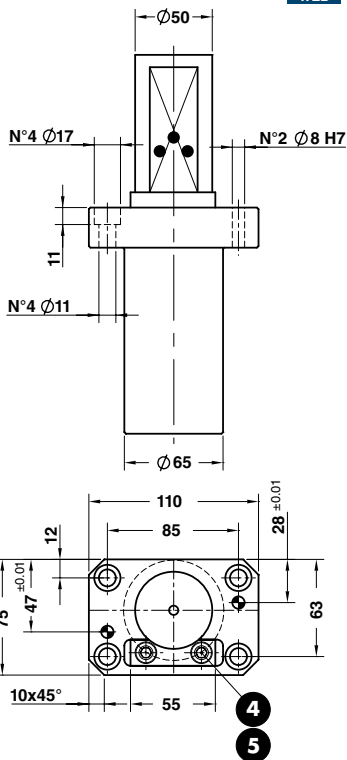
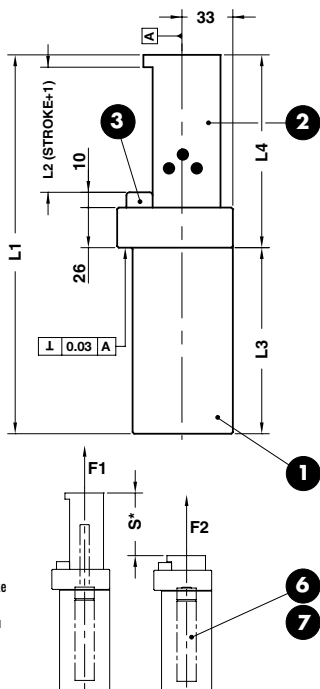
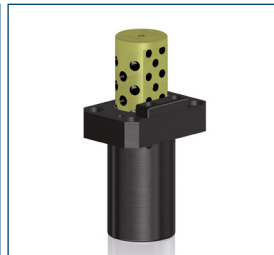

\* Stroke  
Hub  
Corsa

ORDER EXAMPLE	Art.	S=50	F1=50
	C16.31.	50	050

OMCR CODE	F1 (daN)	F2 (daN)	L1	L2	L3	L4	S
C16.31.50050	50	86	196	51	101	95	50
C16.31.50100	100	172	196	51	101	95	50
C16.31.50150	150	258	196	51	101	95	50
C16.31.50200	200	344	196	51	101	95	50
C16.31.80050	50	86	256	81	131	125	80
C16.31.80100	100	172	256	81	131	125	80
C16.31.80150	150	258	256	81	131	125	80
C16.31.80200	200	344	256	81	131	125	80

## SPRING PLUNGER - FEDERNE DRUCKSTÜCKE - ESPULSORE A MOLLA

Spring plungers can be fitted/  
removed by means of the slot or  
internal hexagon.

Montage/demontage mit  
Innensechskant und Schlitz  
möglich.

Il montaggio/smontaggio  
avviene sia tramite l'esagono  
incassato, che tramite l'intaglio  
frontale.

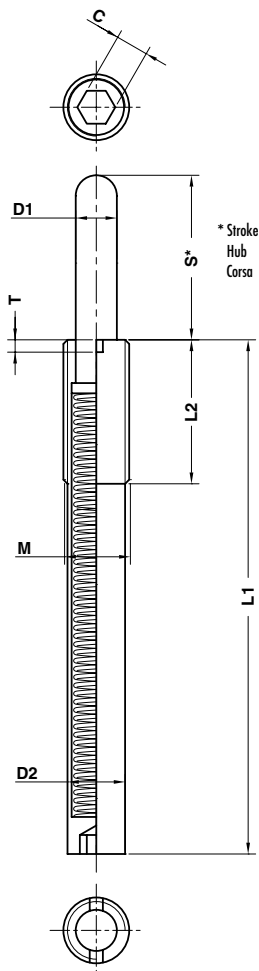
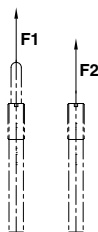

\* Stroke  
Hub  
Corsa

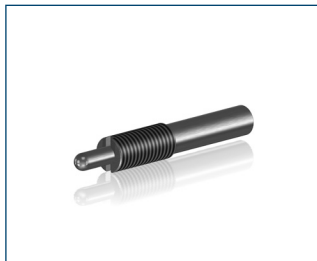

### Notes

**Material:** Steel

ORDER EXAMPLE 	Art.	M=M16	S=40
	C16.40.	M16	40

OMCR CODE	C	D1	D2	F1 (N)	F2 (N)	L1	L2	M	S	T
C16.40.M1210	4	5,5	9,5	7	40	45	35	M12	10	2
C16.40.M1615	5	8	13,4	15	80	60	35	M16	15	3
C16.40.M1620	5	8	13,4	17	80	85	35	M16	20	3
C16.40.M1630	5	8	13,4	20	80	125	35	M16	30	3
C16.40.M1640	8	8	13,4	20	80	125	35	M16	40	3
C16.40.M1650	8	8	13,4	30	100	155	35	M16	50	3
C16.40.M1660	8	8	13,4	20	80	155	35	M16	60	3
C16.40.M2415	8	10	19,6	40	200	60	45	M24	15	3
C16.40.M3020	12	15	22,5	50	300	80	45	M30	20	3

## SPRING PLUNGER - FEDERNE DRUCKSTÜCKE - ESPULSORE A MOLLA

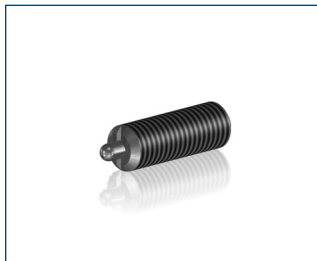
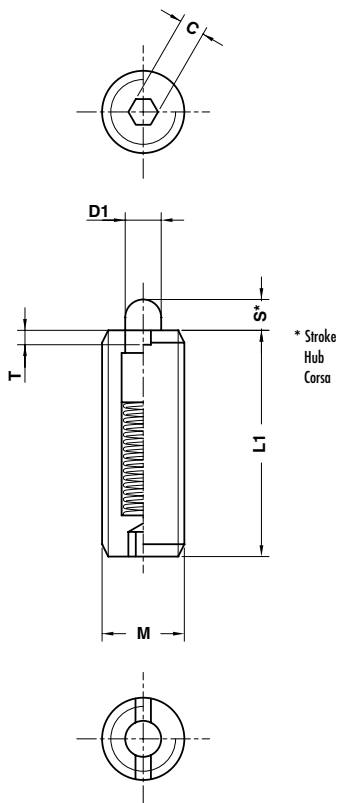

**Notes**  
**Material:** Steel

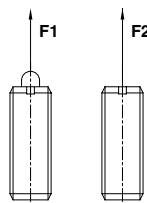

	Art.	M=M3
	C16.45.	M03

OMCR CODE	C	D1	F1 (N)	F2 (N)	L1	M	S	T
C16.45.M03	0,7	1	2	4	10	M3	1,5	0,5
C16.45.M04	1,3	1,6	5	16	12	M4	2	0,6
C16.45.M05	1,5	2	6	19	20	M5	3	0,8
C16.45.M06	2	2,5	6	19	25	M6	3	0,9
C16.45.M08	2,5	3,1	10	39	25	M8	4	1,4
C16.45.M10	3	3,8	10	39	30	M10	5	1,4
C16.45.M12	4	5,5	12	53	30	M12	5	2



## SPRING RAMS - FEDERBOLZEN - SOLLEVATORE

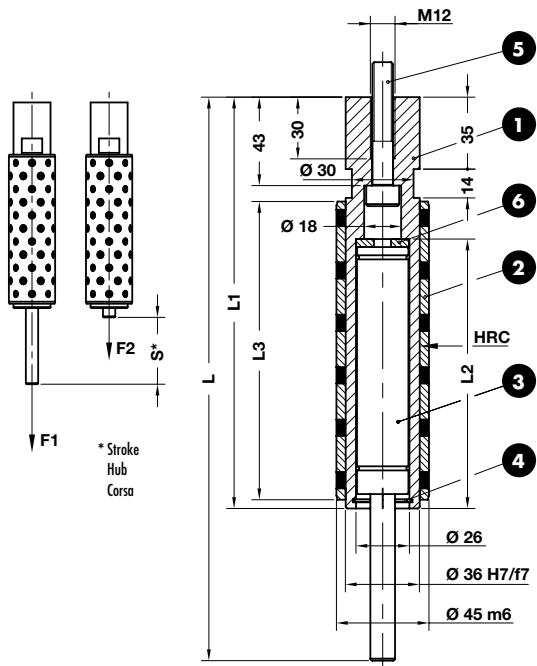

### Notes

- 1** Material: CK45 - HRC: 58÷62
- 2** Material: Bronze+Graphite - HB>190
- 3** Gas Spring
- 4** DIN 472
- 5** M10x60 DIN 912
- 6** Material: 90MnCrV8 - HRC: 54÷60

	Art.	S=50	F1=50
	C16.50.	50	050

OMCR CODE	F1 (daN)	F2 (daN)	L	L1	L2	L3	S
C16.50.50050	50	68	240	182	118	115	50
C16.50.50100	100	136	240	182	118	115	50
C16.50.50150	150	204	240	182	118	115	50
C16.50.50200	200	272	240	182	118	115	50
C16.50.65050	50	68	274	200	135	145	65
C16.50.65100	100	136	274	200	135	145	65
C16.50.65150	150	204	274	200	135	145	65
C16.50.65200	200	272	274	200	135	145	65
C16.50.80050	50	68	314	220	155	170	80
C16.50.80100	100	136	314	220	155	170	80
C16.50.80150	150	204	314	220	155	170	80
C16.50.80200	200	272	314	220	155	170	80

## ELASTOMER SPRING - ELASTOMERFEDER - MOLLA IN ELASTOMERO

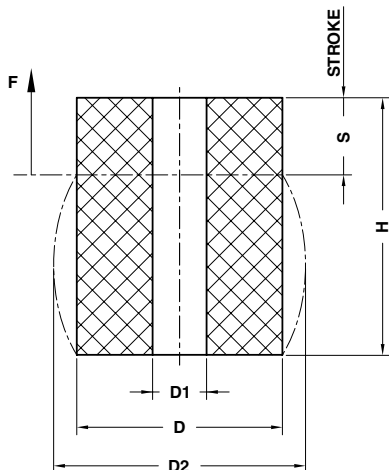

S = max. 30% H

**Notes**

**Material:** Elastomer 92SH

	Art.	D=63	H=80
	C17.10.	063	080

D	16	20	25	32	40	50	63	80	100	125
D1	6,5	8,5	10,5	13,5	13,5	17	17	21	21	27
D2	19	26	30	41	50	62	78	98	120	152
F (daN)	130	200	300	580	1250	1700	2600	4300	5900	9900

H	S									
16	4,8	•	•	•	•					
20	6	•	•	•	•	•				
25	7,5	•	•	•	•	•	•			
32	9,6	•	•	•	•	•	•	•		
40	12		•	•	•	•	•	•	•	
50	15			•	•	•	•	•	•	•
63	19				•	•	•	•	•	•
80	24					•	•	•	•	•
100	30						•	•	•	•
125	37,5							•	•	•
160	48								•	•

**LOAD DIAGRAMS FOR ELASTOMER SPRINGS 92SH  
KRAFT-WEG-DIAGRAMM ELASTOMERFEDERN 92SH  
DIAGRAMMI DI CARICO MOLLE IN ELASTOMERO 92SH**

Standard OMCR

**Ø16 x Ø6,5 x H**

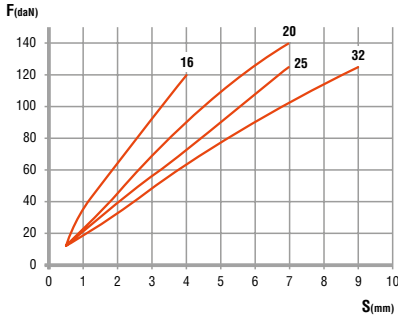

**Ø20 x Ø8,5 x H**

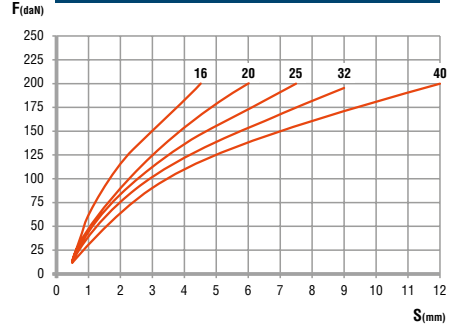

**Ø25 x Ø10,5 x H**

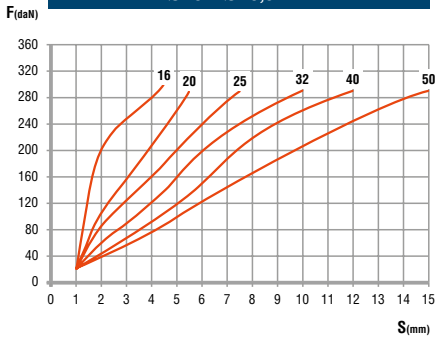

**Ø32 x Ø13,5 x H**

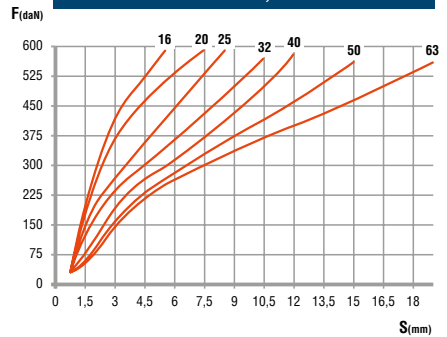

**Ø40 x Ø13,5 x H**

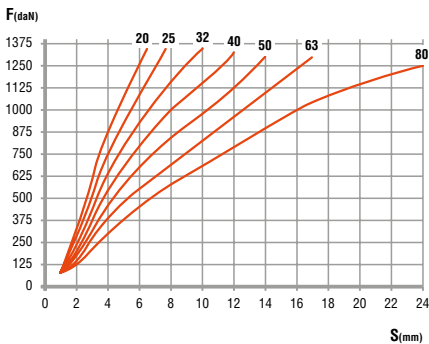

**LOAD DIAGRAMS FOR ELASTOMER SPRINGS 92SH**  
**KRAFT-WEG-DIAGRAMM ELASTOMERFEDERN 92SH**  
**DIAGRAMMI DI CARICO MOLLE IN ELASTOMERO 92SH**

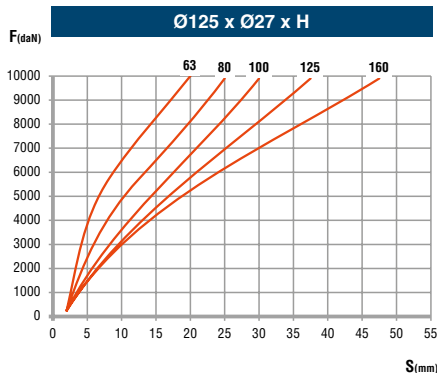
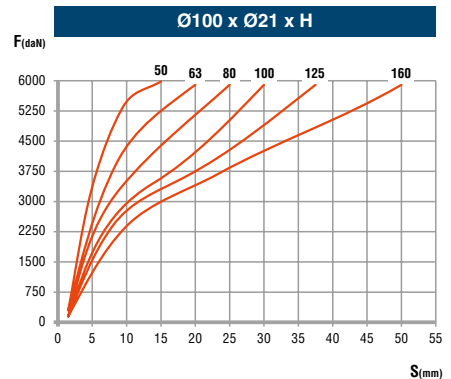
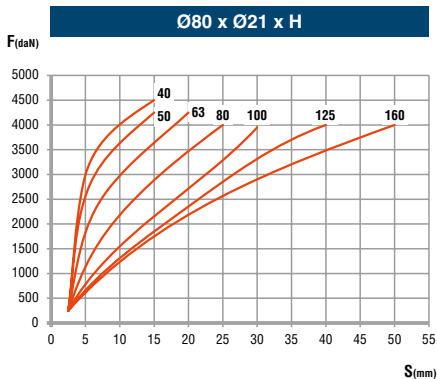
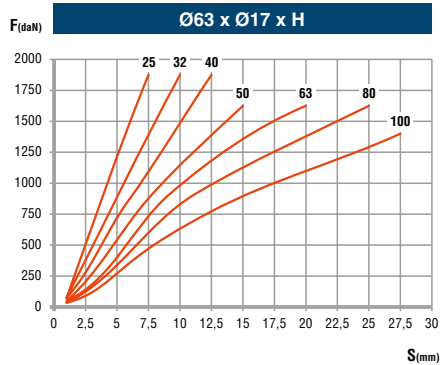
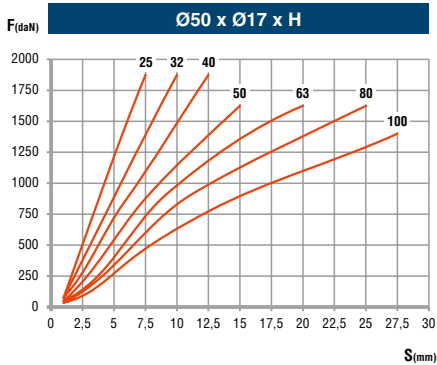

## ELASTOMER SPRING - ELASTOMERFEDER - MOLLA IN ELASTOMERO

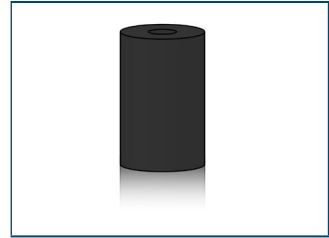
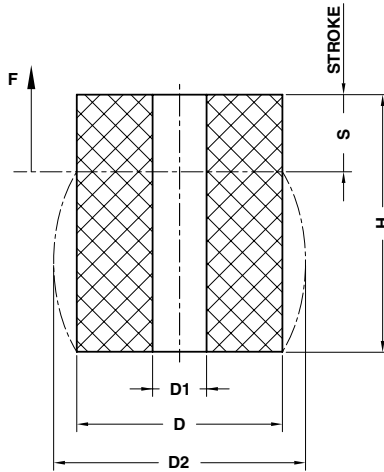

### Notes

**Material:** Elastomer 70 Shore

Standard OMCR

	Art.	D=63	H=80
	C17.11.	063	080

D	16	20	25	32	40	50	63	80	100	125
D1	6,5	8,5	10,5	13,5	13,5	17	17	21	21	27
D2	19	26	30	41	50	62	78	98	120	152
F (daN)	40	50	90	225	400	600	1000	1800	3000	5000

H	S										
12	4,8	•									
16	6,4	•	•								
20	8	•	•	•							
25	10	•	•	•							
32	12,8		•	•	•	•	•	•	•	•	•
40	16			•	•	•	•	•	•	•	•
50	20				•	•	•	•	•	•	•
63	25,2				•	•	•	•	•	•	•
80	32					•	•	•	•	•	•
100	40						•	•	•	•	•
125	50							•	•	•	•
160	64										•

**LOAD DIAGRAMS FOR ELASTOMER SPRINGS 70 SHORE**  
**KRAFT-WEG-DIAGRAMM ELASTOMERFEDERN 70 SHORE**  
**DIAGRAMMI DI CARICO MOLLE IN ELASTOMERO 70 SHORE**

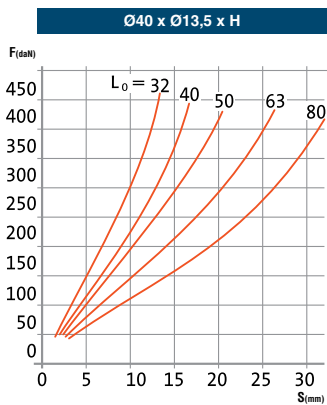
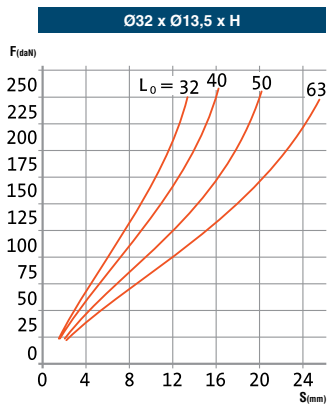
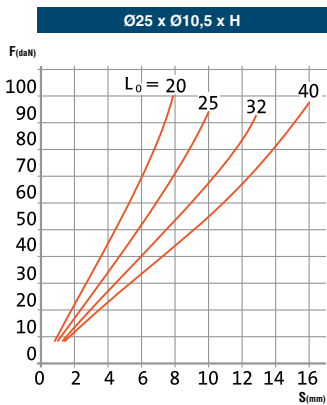
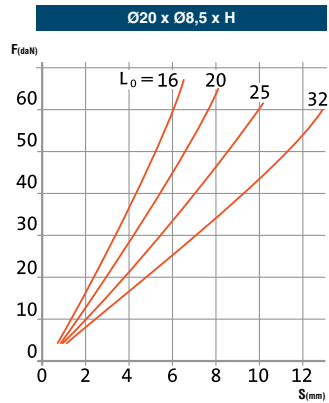
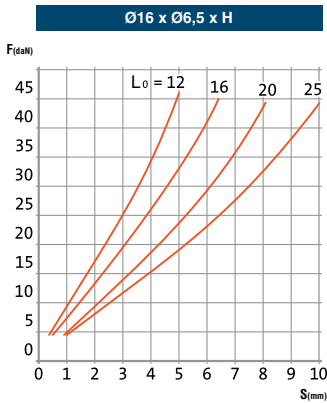

**LOAD DIAGRAMS FOR ELASTOMER SPRINGS 70 SHORE**  
**KRAFT-WEG-DIAGRAMM ELASTOMERFEDERN 70 SHORE**  
**DIAGRAMMI DI CARICO MOLLE IN ELASTOMERO 70 SHORE**

Standard OMCR

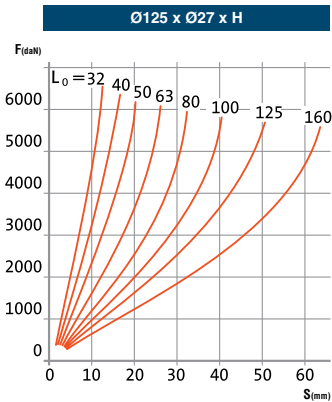
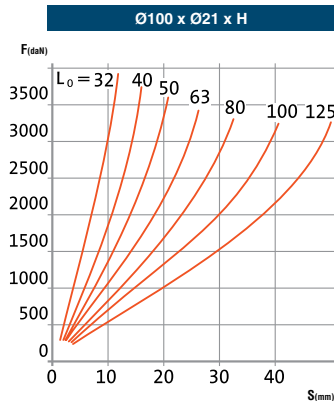
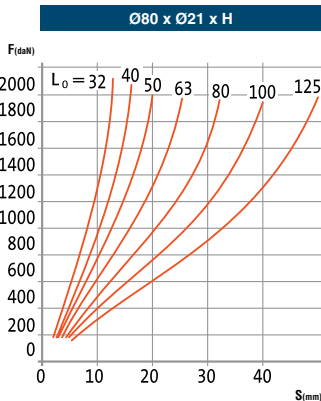
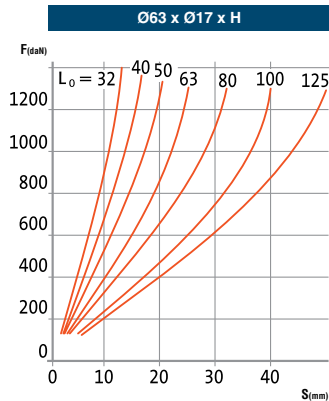
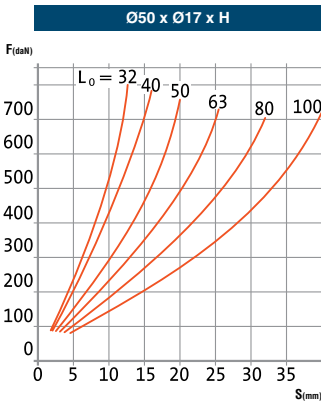

## ELASTOMER STRIPPER - ABSTREIFER - ESTRATTORE PER PUNZIONI

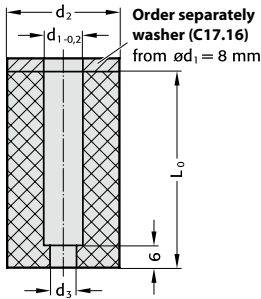

### Notes

**Material:** Elastomer 95SH

### Application example

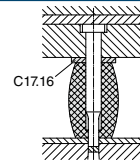

Art.	D1 = 4	L
C17.15.	04	39

CODE	d1	d2	d3	L	CODE	d1	d2	d3	L
C17.15.0439	4	17	1,6	39	C17.15.1339	13	26	3	39
C17.15.0447	4	17	1,6	47	C17.15.1347	13	26	3	47
C17.15.0456	4	17	1,6	56	C17.15.1356	13	26	3	56
C17.15.0639	6	19	1,6	39	C17.15.1639	16	30	3	39
C17.15.0647	6	19	1,6	47	C17.15.1647	16	30	3	47
C17.15.0656	6	19	1,6	56	C17.15.1656	16	30	3	56
C17.15.0839	8	21	3	39	C17.15.2039	20	38	3	39
C17.15.0847	8	21	3	47	C17.15.2047	20	38	3	47
C17.15.0856	8	21	3	56	C17.15.2056	20	38	3	56
C17.15.1039	10	23	3	39	C17.15.2539	25	50	3	39
C17.15.1047	10	23	3	47	C17.15.2547	25	50	3	47
C17.15.1056	10	23	3	56	C17.15.2556	25	50	3	56

# C17.16

## WASHER - SCHEIBE - RONDELLA

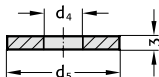

Art.	D4 = 8,5
C17.16.	085

CODE	d4	d5	CODE	d4	d5	Notes
C17.16.085	8,5	21	C17.16.205	20,5	38	<b>Material:</b> Steel
C17.16.105	10,5	23	C17.16.255	25,5	50	
C17.16.130	13	26	C17.16.325	32,5	55	
C17.16.135	13,5	26	C17.16.385	38,5	60	
C17.16.165	16,5	30	C17.16.405	40,5	63	



ELASTOMER STRIPPER - ABSTREIFER - ESTRATTORE PER PUNZONI

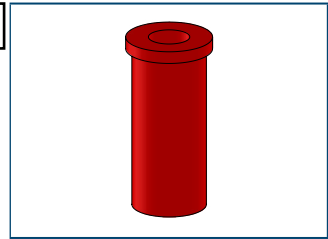
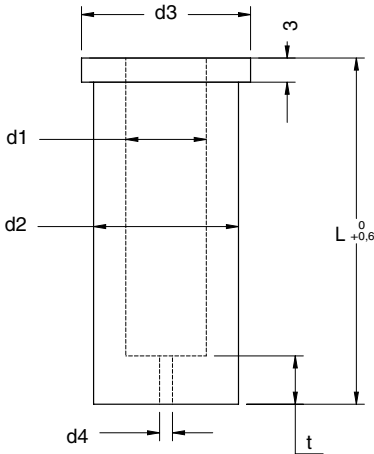

Notes

Material: Elastomer 95SH A

Application example

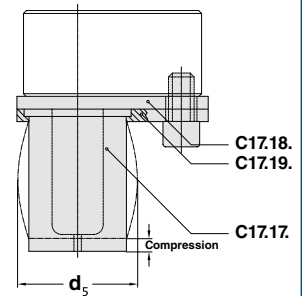

\* values for the stripping force are dependent on a number of parameters (e.g. lubricant, temperature etc.) and may vary from those given here.  
 \*\* max spring travel should not exceed 15% of the length

ORDER EXAMPLE	Art.	d1	L
	C17.17.	10	43

CODE	d1	d2	d3	d4	d5	t	L
C17.17.1043	10	18	21	1,6	22	6	43
C17.17.1053	10	18	21	1,6	22	6	53
C17.17.1063	10	18	21	1,6	22	6	63
C17.17.1343	13	23	26	3	26,5	6	43
C17.17.1353	13	23	26	3	26,5	6	53
C17.17.1363	13	23	26	3	26,5	6	63
C17.17.1373	13	23	26	3	26,5	6	73
C17.17.1643	16	28	31	3	34	6	43
C17.17.1653	16	28	31	3	34	6	53
C17.17.1663	16	28	31	3	34	6	63
C17.17.1673	16	28	31	3	34	6	73
C17.17.2043	20	33	36	3	38	7	43
C17.17.2053	20	33	36	3	38	7	53
C17.17.2063	20	33	36	3	38	7	63
C17.17.2073	20	33	36	3	38	7	73
C17.17.2543	25	40	43	3	47,5	7	43
C17.17.2553	25	40	43	3	47,5	7	53
C17.17.2563	25	40	43	3	47,5	7	63
C17.17.2573	25	40	43	3	47,5	7	73

STROKE**	3mm	6mm	9mm	3mm	6mm	9mm	3mm	6mm	9mm	3mm	6mm	9mm
LENGHT	43	43	43	53	53	53	63	63	63	73	73	73
d1	Stripping forces (N)*											
10	1060	1820	-	900	1650	-	720	1450	1860	-	-	-
13	1700	2850	-	1460	2610	-	1170	2320	2910	930	2080	2500
16	2310	3900	-	1990	3560	-	1590	3150	3980	1270	2810	3440
20	2900	4900	-	2500	4470	-	2000	3950	5000	1590	3420	4330
25	4440	7520	-	3810	6860	-	3050	6050	7680	2420	5390	6780

## STRIPPING UNIT- PRESSURE PLATE ABSTREIFER - DRUCKPLATTE PIASTRA PREMENTE DELL'ESTRATTORE

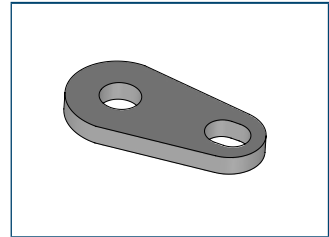
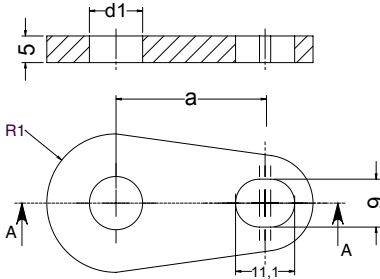

### Notes

**Material:** S137

	Art.	d1 = 10
	C17.18.	010

CODE	d1	R1	A
C17.18.010	10	13	28
C17.18.013	13	15,5	31
C17.18.016	16	18	32,9
C17.18.020	20	20,5	34,8
C17.18.025	25	24	39,8

## STRIPPING UNIT - MOUNTING PLATE ABSTREIFER - HALTEPLATTE PIASTRA DI FISSAGGIO DELL'ESTRATTORE

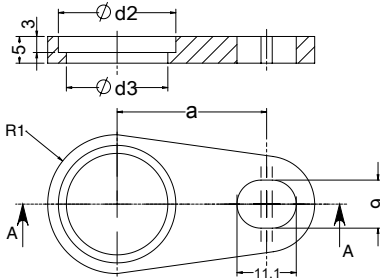

### Notes

**Material:** S137

	Art.	d1 = 10
	C17.19.	010

CODE	d1	d2	d3	R1	A
C17.19.010	10	22	19	13	28
C17.19.013	13	27	24	15,5	31
C17.19.016	16	32	29	18	32,9
C17.19.020	20	37	34	20,5	34,8
C17.19.025	25	44	41	24	39,8

## ELASTOMER CAP - ELASTOMERDRUCKSTÜCK - PUNTALINO IN ELASTOMERO

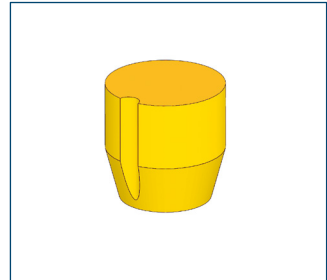
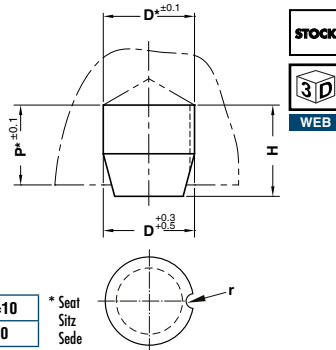

ORDER EXAMPLE	Art.	D=6	H=10
	C17.20.	06	10

\* Seat  
Sitz  
Sede

OMCR CODE	D	F max. (N)	H	P	r
C17.20.0610	6	100	10	8	0
C17.20.1015	10	450	15	13	1
C17.20.1625	16	1500	25	21	1,5
C17.20.2425	24	3000	25	20	2
C17.20.3035	30	3000	35	30	2,5
C17.20.3232	32	12000	32	26	3
C17.20.3940	39,5	25000	40	34	3
C17.20.4040	40	25000	40	35	3

### Notes

**Material:** Elastomer 90SH

Standard OMCR

# C17.21

## SHOCK ABSORBER - HALTELEMENT - AMMORTIZZATORE

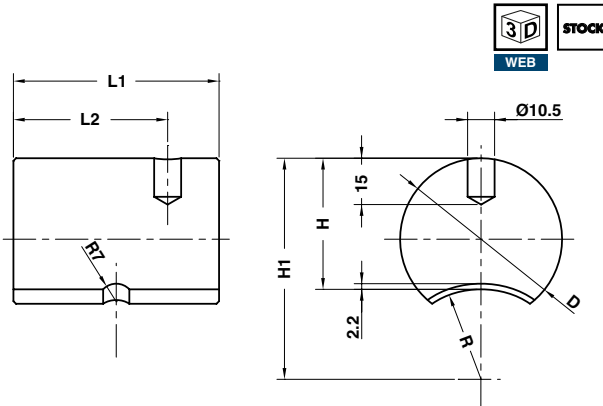

ORDER EXAMPLE	Art.	D=50	L1=80
	C17.21.	50	80

OMCR CODE	D	H	H1	L1	L2	R
C17.21.4060	40	32	50	60	45	18
C17.21.5080	50	40	63	80	60	23
C17.21.6380	63	51	86	80	60	35

### Notes

**Material:** Elastomer 92SH

### Application example

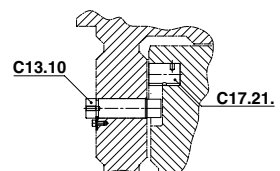

ANTI-REBOUND ELASTOMER - DÄMPFUNGSELEMENT - AMMORTIZZATORE ANTIRIMBALZO

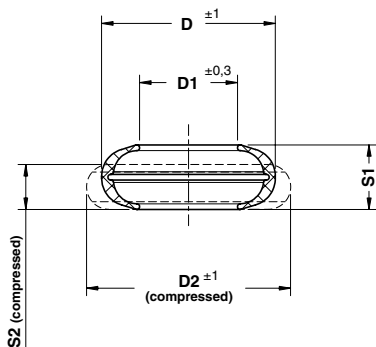

Notes

**Material:** CO-Polyester Elastomer

ORDER EXAMPLE	Art.	D=32,1	S1=10,8
	C17.27.	321	108

OMCR CODE	D	D1	D2	F max. (daN)	S1	S2
C17.27.262077	26,4	16,3	28,4	550	7,8	5,5
C17.27.321108	32,1	20,3	35,1	900	10,8	6,0
C17.27.463177	45,8	25,3	49,8	2000	17,0	11,6
C17.27.546216	54,6	30,3	61,8	3000	21,3	13,0
C17.27.618215	61,8	36,3	69,9	4600	21,5	13,2
C17.27.782300	78,5	42,8	89,0	7500	29,4	17,9

**ELASTOMER SPRING PIN - AUFNAHMEBOLZEN - PERNO PER MOLLE IN ELASTOMERO**

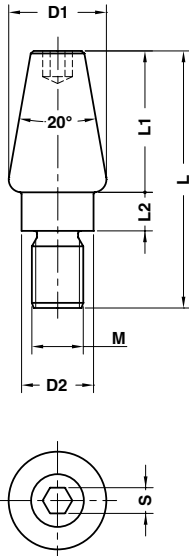

**Notes**  
**Material:** CK45

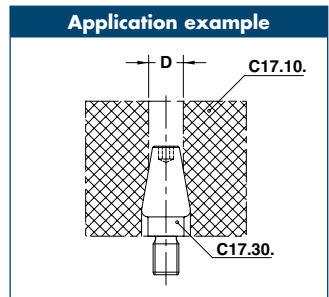

Standard OMCR

ORDER EXAMPLE	Art.	D1	M=M16
	C17.30.	32	M16

OMCR CODE	D	D1	D2	L	L1	L2	M	S
C17.30.28M12	17	28	19	56	30	8	M12	6
C17.30.32M16	21	32	22	74	40	10	M16	8
C17.30.38M20	27	38	28	100	55	15	M20	10

## WASHER FOR ELASTOMER SPRINGS - FEDERSCHEIBE - RONDELLA PER MOLLE IN ELASTOMERO

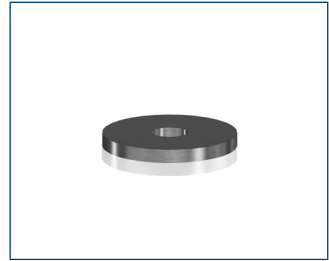

### Notes

**Material:** CK45

### Application example

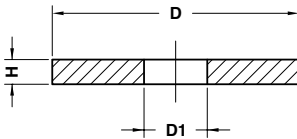
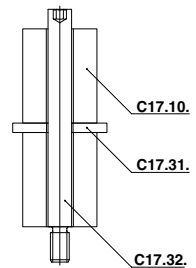

	Art.	D=20
	C17.31.	020

OMCR CODE	D	D1	H
C17.31.020	20	6,5	4
C17.31.025	25	8,5	4
C17.31.030	30	10,5	5
C17.31.040	40	13,5	5
C17.31.050	50	13,5	5
C17.31.060	60	16,5	6
C17.31.080	80	16,5	6
C17.31.100	100	20,5	8
C17.31.120	120	20,5	8
C17.31.150	150	26	8

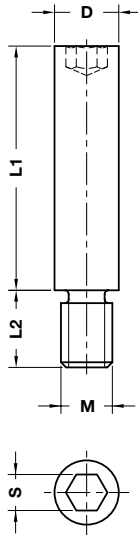

**Notes**  
**Material:** CK45

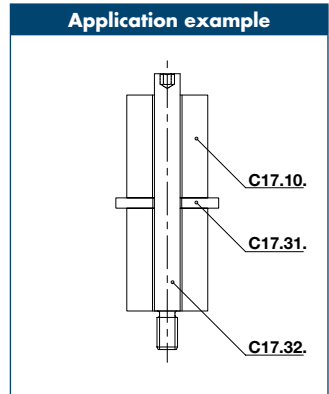

Standard OMCR

ORDER EXAMPLE	Art.	D=6	L1=20
	C17.32.	06	020

D	6	8	10	13	16	20	25
L2	6	9	15	15	18	25	30
M	M4	M6	M8	M10	M12	M16	M20
S	3	4	5	6	8	10	14
L1							
20	•	•	•				
25	•	•	•				
32	•	•	•	•			
40		•	•	•	•	•	•
50		•	•	•	•	•	•
63			•	•	•	•	•
80				•	•	•	•
95				•	•	•	•
118					•	•	•
140					•		•
180							•

**Application example**

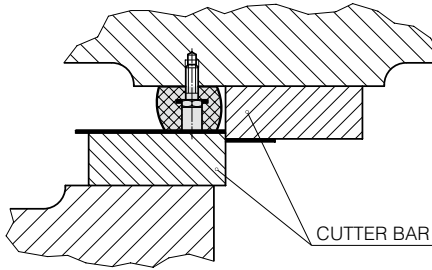

**Notes**

**Material:** Elastomer 70 SH

**C17.40.11270**

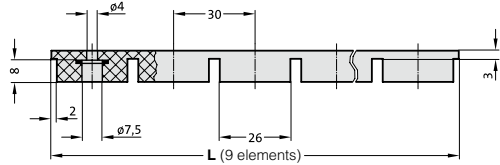
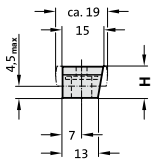

**C17.40.16270**

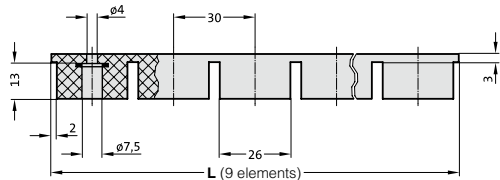
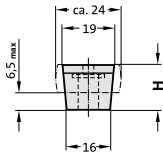

**C17.40.27306**

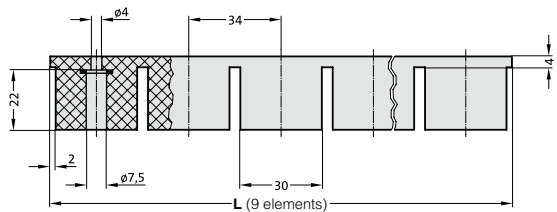
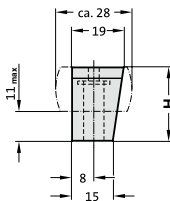

Art.	H=11,5	L=270
C17.40.	11	270

OMCR CODE	H	L
C17.40.11270	11,5	270
C17.40.16270	16,5	270
C17.40.27306	27	306



ANTI-REBOUND ELASTOMER - DÄMPFUNGSELEMENT - AMMORTIZZATORE ANTIRIMBALZO

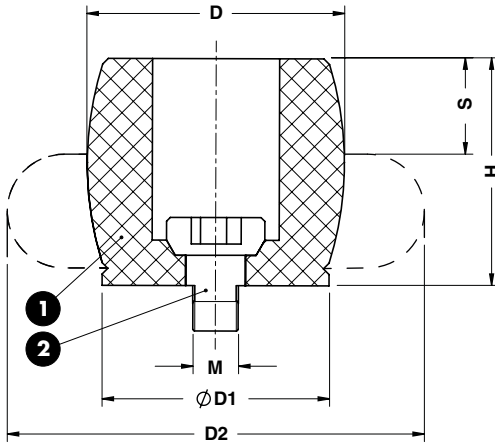

- Notes**
- 1 **Material:** CO-Polyester Elastomer
  - 2 Screw

Standard OMCR

	Art.
	C17.51.1211

OMCR CODE	D	D1	D2	M	H	S	Nm/S
C17.51.1211	12	11	15	3	11	4	2
C17.51.1716	17	15	22	4	16	6	6
C17.51.2118	21	18	26	5	18	7	10
C17.51.2219	22	19	27	6	19	6	11.5
C17.51.2826	28	25	36	6	26	9	29
C17.51.3430	34	30	43	6	30	10	48
C17.51.3733	37	33	48	8	33	12	65

ANTI-REBOUND ELASTOMER - DÄMPFUNGSELEMENT - AMMORTIZZATORE ANTIRIMBALZO

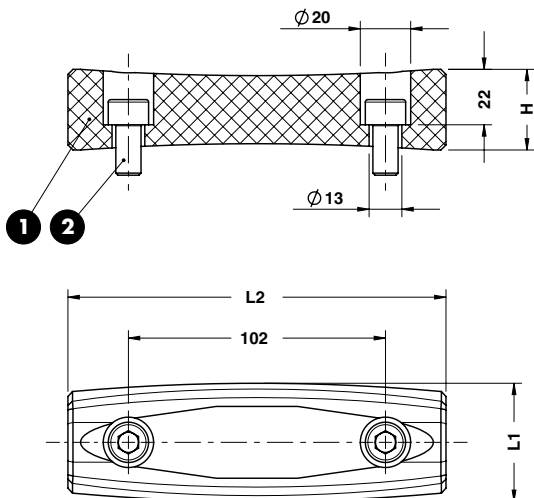

WEB

Notes

- 1 Material: CO-Polyester Elastomer
- 2 M10 DIN 912

ORDER EXAMPLE	Art.	H=32	L1=47	L2=150
	C17.52.	32	47	150

OMCR CODE	H	L1	L2
C17.52.2952153	29	52	153
C17.52.3247150	32	47	150

ANTI-REBOUND SLIDE STOP - ARRETERUNG GEGEN RÜCKFEDERUNG - ARRESTO ANTRIMBALZO

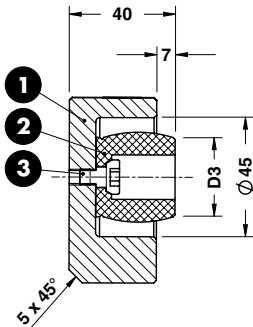
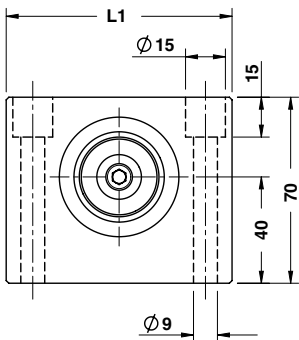

Notes

- 1 Material: CK45
- 2 C17.51
- 3 Screw

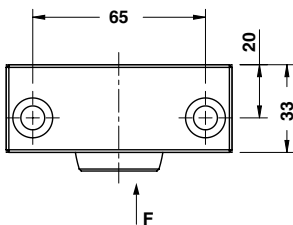

ORDER EXAMPLE	Art.	L1=85	D3=30
	C18.05.	85	30

\* Maximum absorbed energy  
Energieaufnahme  
Massima energia assorbita

OMCR CODE	L1	D3	F max (kN)	Max Energy Absorbed (J)*	Max Stroke (mm)
C18.05.8530	85	30	3,75	8	7

Application example

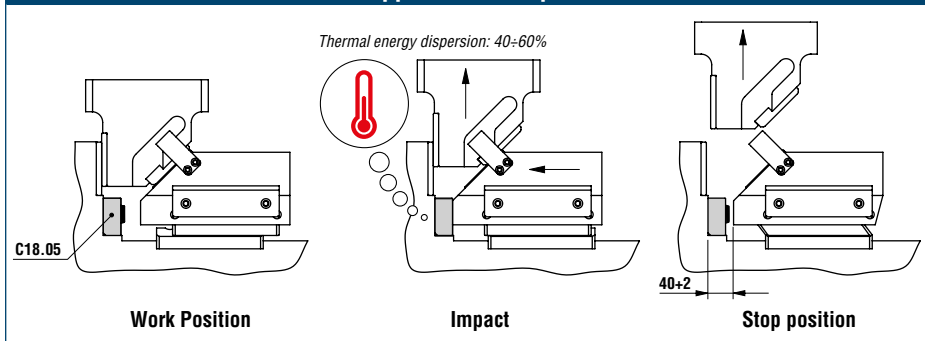

SLIDE STOP BLOCK - SCHIEBERANSCHLAG - ARRESTO SLITTA

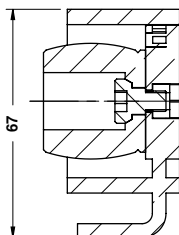
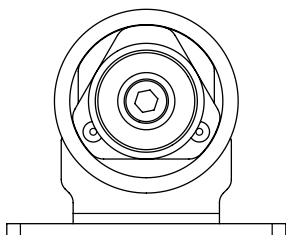

- Notes**
- 3 Material: Si37
  - 4 Material: CO-Polyester Elastomer
  - 5 M6x12 DIN 912

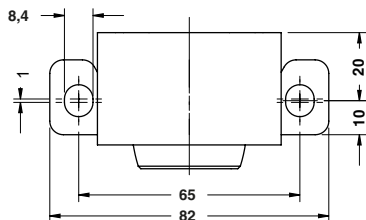

ORDER EXAMPLE	Art.
	C18.06.01

OMCR CODE	F max (kN)	Max Energy Absorbed (J)*	Max Stroke (mm)
C18.06.01	3,75	8	7

ANTI-REBOUND SLIDE STOP - ARRETERUNG GEGEN RÜCKFEDERUNG - ARRESTO ANTIRIMBALZO

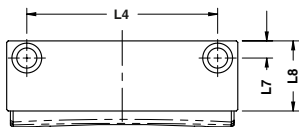
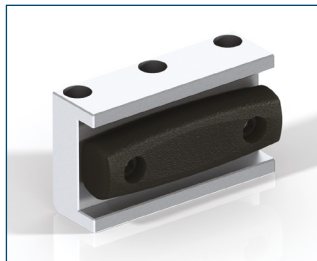
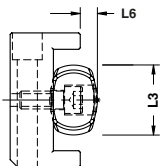
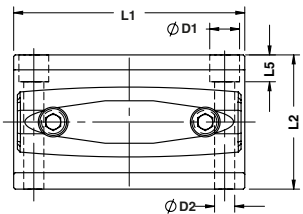

FORM A

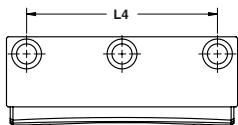

FORM B



Notes

- 1 Material: CK45
- 2 C17.52
- 3 M10 DIN 912

\* Maximum absorbed energy  
Energieaufnahme  
Massima energia assorbita



Art.	L1=155	L2=90	L3=52
C18.07.	155	90	52

OMCR CODE	F max (kN)	Max Energy Absorbed (J)*	Max Stroke (mm)	Nr. of screws	FORM
C18.07.1558047	155	210	10,3	2	A
C18.07.1559047	47	160	14	3	B
C18.07.1559052	370	230	7	2	A

OMCR CODE	L1	L2	L3	L4	L5	L6	L7	D1	D2
C18.07.1558047	155	80	47	130	9	10,3	10	15	9
C18.07.1559047	155	90	47	128	18	14	11,5	20	13,5
C18.07.1559052	155	90	52	130	19	7	10	15	9

Application example

Thermal energy dispersion: 40-60%

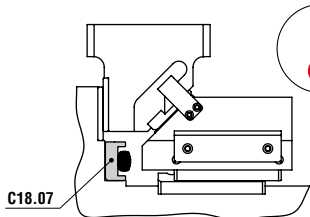

Work Position

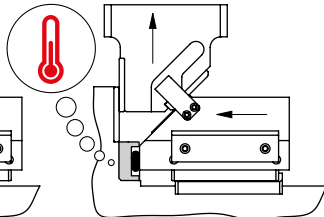

Impact

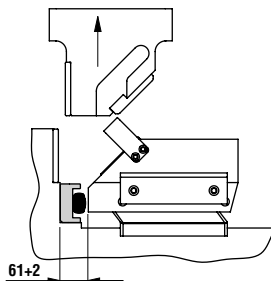

Stop position

## SLIDE STOP BLOCK - SCHIEBERANSCHLAG - ARRESTO SLITTA

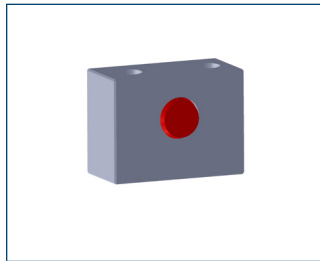
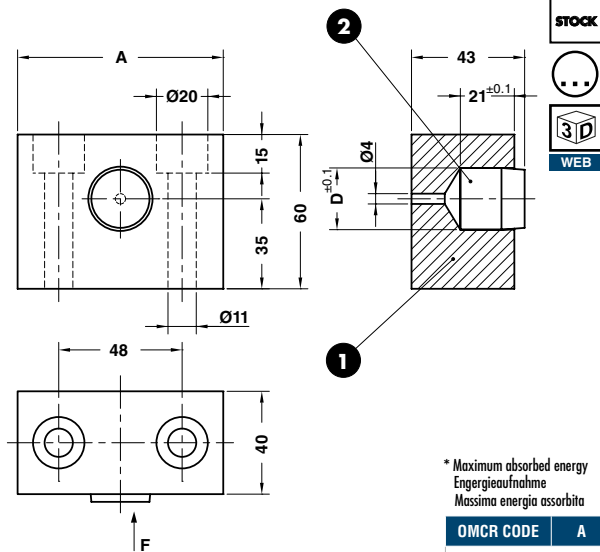

- Notes**
- 1 **Material:** CK45
  - 2 C17.20.2425

\* Maximum absorbed energy  
Energieaufnahme  
Massima energia assorbita

ORDER EXAMPLE	Art.	A=80	D=24
	C18.10.	80	24

OMCR CODE	A	D	F max (kN)	Max Energy Absorbed (J)*
C18.10.8024	80	24	3	4,8

# C18.11

## SLIDE STOP BLOCK - SCHIEBERANSCHLAG - ARRESTO SLITTA

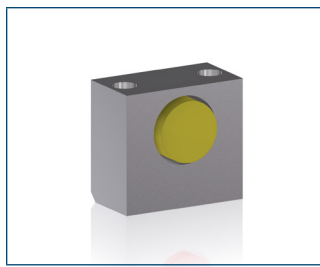
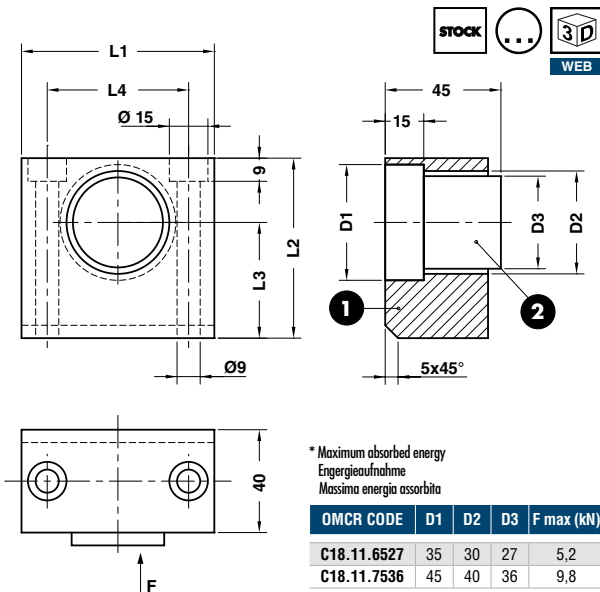

- Notes**
- 1 **Material:** CK45
  - 2 **Material:** Elastomer 90 SH

\* Maximum absorbed energy  
Energieaufnahme  
Massima energia assorbita

ORDER EXAMPLE	Art.	L1=65	D3=27
	C18.11.	65	27

OMCR CODE	D1	D2	D3	F max (kN)	L1	L2	L3	L4	Max Energy Absorbed (J)*
C18.11.6527	35	30	27	5,2	65	60	40	45	13
C18.11.7536	45	40	36	9,8	75	70	45	55	24,5

**SLIDE STOP BLOCK - SCHIEBERANSCHLAG - ARRESTO SLITTA**

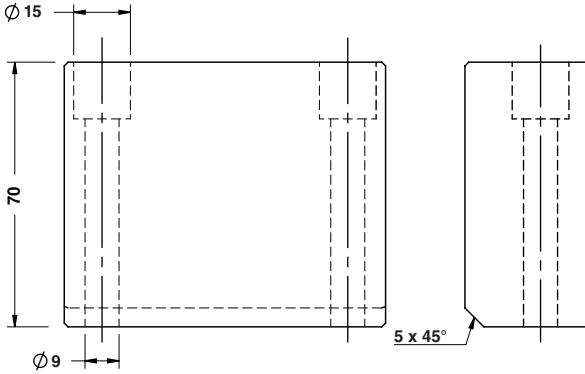

**Notes**

**Material:** CK45

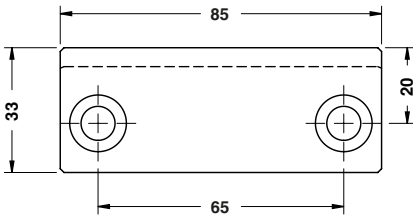

Standard OMCR

	Art.
	C18.12.01
<b>OMCR CODE</b>	
C18.12.01	

POSITIVE RETURN PLATE - ZWANGSRÜCKHOLER - GANCIO DI SICUREZZA

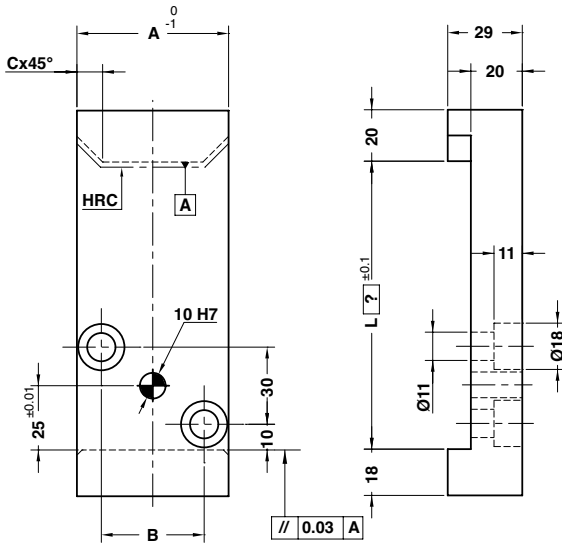

Notes

Material: CK45 - HRC: 52±54

Application example

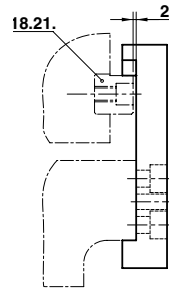

ORDER EXAMPLE	Art.	A=35	L=?
	C18.20.	35	80

OMCR CODE	A	B	C
C18.20.35	35	15	7
C18.20.60	60	40	10



KEY - PASSFEDER - CHIAVETTA

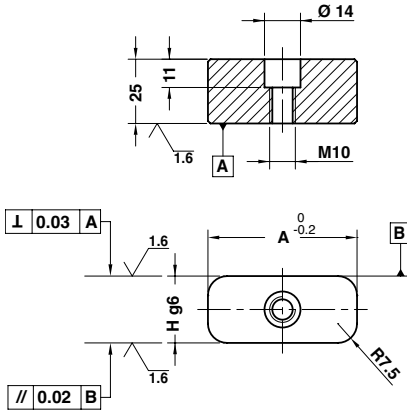

\* For adjustment  
Für umrüsten  
Per adattamento



**Notes**

**Material:** 90MnCrV8 - **HRC:** 58÷60

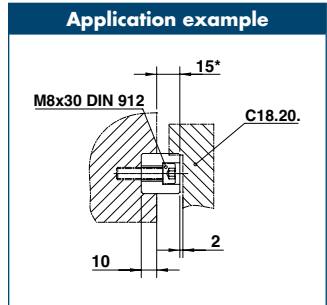

ORDER EXAMPLE	Art.	H=26	A=35
	C18.21.	26	35

OMCR CODE	H	A
C18.21.2635	26	35
C18.21.2660	26	60

Standard OMCR

CAM BLANK-HOLDER GUIDE - FÜHRUNG FÜR ZIEHKISSEN - GUIDA PER PREMILAMIERA

**Notes**

**Material:** Bronze + Graphite - HB >190

STOCK

↔

3D

WEB

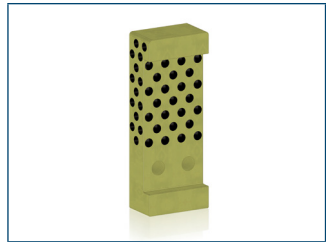

"FORM A"

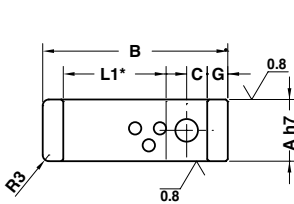

"FORM B"

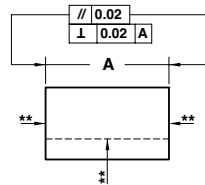
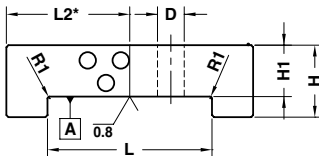
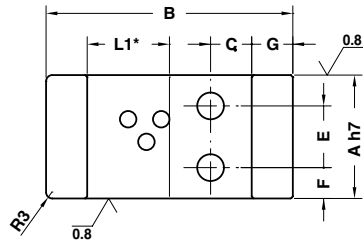

ORDER EXAMPLE	Art.	A=30	B=70
	C18.25.	030	070

\* Surface with solid lubricant / Oberfläche mit Festschmierstoff / Superficie con inserti autolubrificanti  
 \*\* Sliding Surface / Geißfläche / Superficie di Scorrimento

OMCR CODE	A	B	C	D	E	F	G	H	H1	L	L1	L2	FORM
C18.25.030070	30	70	10	11	-	-	10	17	12	50	30	40	A
C18.25.030090	30	90	10	11	-	-	10	17	12	70	50	60	A
C18.25.045070	45	70	10	11	22	11,5	10	25	15	50	30	40	B
C18.25.045090	45	90	10	11	22	11,5	10	25	15	70	50	60	B
C18.25.060120	60	120	20	13	30	15	20	35	25	80	40	60	B
C18.25.060140	60	140	20	13	30	15	20	35	25	100	60	80	B
C18.25.060160	60	160	20	13	30	15	20	35	25	120	80	100	B

**COUPLING PLATE – BEFESTIGUNGSPLATTE - STAFFA DI REAZIONE**

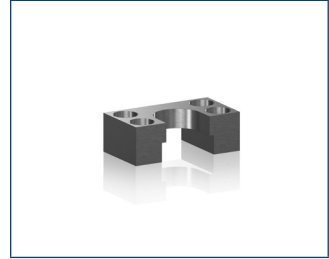
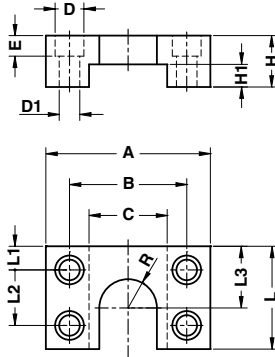

**Notes**  
**Material: CK45**

Standard OMCR

	Art.	A=80	R=14
	C18.30.	080	14

OMCR CODE	A	B	C	D	D1	E	H	H1	L	L1	L2	L3	R
C18.30.08014	080	57	38	18	11	10	25	11	50	11,5	27	30	14
C18.30.10020	100	75	50	20	13	12	32	15	55	12,5	30	35	20
C18.30.12025	120	88	60	26	17	16	40	20	65	16	33	45	25
C18.30.15033	150	114	80	33	22	26	45	20	100	18	64	64	33

## COUPLING NUT - KUPPLUNGSMUTTER - AGGANCIO STAFFA

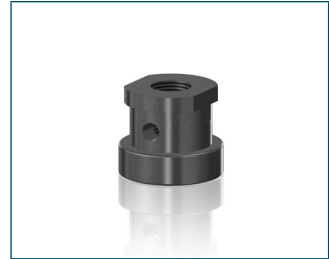
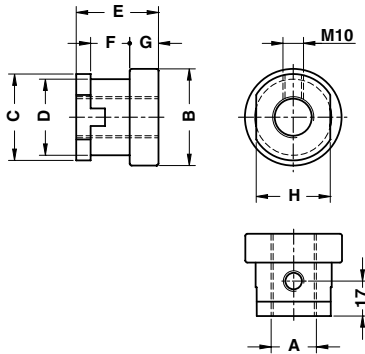

### Notes

**Material:** CK45

	Art.	D=47	A=M27
	C18.31.	47	M27

OMCR CODE	A	B	C	D	E	F	G	H	Air cyl. (I.S.O.) bore size	Using with coupling plate
C18.31.25M10	M10x1,25	35	30	25	30	16	10	24	32	C18.30.08014
C18.31.25M12	M12x1,25	35	30	25	30	16	10	24	40	C18.30.08014
C18.31.37M16	M16x1,5	47	42	37	40	19	14	36	50, 63	C18.30.10020
C18.31.37M20	M20x1,5	47	42	37	40	19	14	36	80, 100	C18.30.10020
C18.31.37M27	M27x2	47	42	37	40	19	14	36	125	C18.30.10020
C18.31.47M27	M27x2	57	52	47	50	24	19	46	125	C18.30.12025
C18.31.47M36	M36x2	57	52	47	50	24	19	46	160, 200	C18.30.12025
C18.31.59M42	M42x2	76	64	59	76	50	19	60	250	C18.30.15033





